



Datacard[®] CD800[™] Card Printer

Installation and Administrator's Guide

January 2017

Part No. 527444-001, Rev. E

Notice

Please do not attempt to operate or repair this equipment without adequate training. Any use, operation or repair you perform that is not in accordance with the information contained in this documentation is at your own risk.

Trademark Acknowledgments

Datacard is a registered trademark and service mark of Entrust Datacard Corporation in the United States and other countries.

Entrust is a registered trademark and service mark in the United States and other countries.

MasterCard is a registered trademark of MasterCard International Incorporated.

Visa is a registered trademark of Visa International Service Association.

All other product names are the property of their respective owners.

Proprietary Notice

The design and information contained in these materials are protected by US and international copyright laws.

All drawings and information herein are the property of Entrust Datacard Corporation. All unauthorized use and reproduction is prohibited.

Entrust Datacard
1187 Park Place
Shakopee, MN 55379
Phone: 952-933-1223
Fax: 952-933-7971
www.entrustdatacard.com

Copyright © 2014–2017 Entrust Datacard Corporation. All rights reserved.

Compliance Statements

Liability

The WARNING and CAUTION labels have been placed on the equipment for your safety. Please do not attempt to operate or repair this equipment without adequate training. Any use, operation, or repair in contravention of this document is at your own risk.

Safety

The following basic safety tips are given to ensure safe installation, operation, and maintenance of Entrust Datacard™ equipment.

- Connect equipment to a grounded power source. Do not defeat or bypass the ground lead.
- Place the equipment on a stable surface (table) and ensure floors in the work area are dry and non-slip.
- Know the location of equipment branch circuit interrupters or circuit breakers and how to turn them on and off in case of emergency.
- Know the location of fire extinguishers and how to use them. ABC type extinguishers may be used on electrical fires.
- Know local procedures for first aid and emergency assistance at the customer facility.
- Use adequate lighting at the equipment location.
- Maintain the recommended temperature and humidity range in the equipment area.

Regulatory Compliance

EMC Compliance Notice

To ensure compliance of the model RX10 retransfer printer to the radiated emissions requirements for class "A" Information Technology Equipment, be sure to use a shielded Ethernet cable when connecting to your network

Notice for USA (FCC Notice)

This equipment has been tested and found to comply with the limits for Class A computing devices, pursuant to Part 15 of FCC rules. These limits are designed to provide reasonable protection against harmful interference when the equipment is operated in a commercial environment. This equipment generates, uses, and can radiate radio frequency energy. If this equipment is not installed and used in accordance with this instruction manual, it may cause harmful interference to radio communications. Operation of this equipment in a residential area is likely to cause harmful interference in which case the user will be required to correct the interference at their own expense. Changes or modifications not expressly approved by the party responsible for compliance could void the user's authority to operate the equipment.

This device complies with Part 15 of the FCC Rules. Operation is subject to the following two conditions: (1) This device may not cause harmful interference, and (2) this device must accept any interference received, including interference that may cause undesired operation.

Notice for Canada

Industry Canada

This digital apparatus does not exceed the Class A limits for radio noise for digital apparatus set out in the Radio Interference Regulations of the Canadian Department of Communications.

Le présent appareil numérique n'émet pas de bruits radioélectriques dépassant les limites applicables aux appareils numériques de la classe A prescrites dans le Règlement sur le brouillage radioélectrique édicté par le ministère des Communications du Canada.

RSS-Gen, Issue 3, December 2010, Section 7.1.3 User Manual Notice

This Device complies with Industry Canada License-exempt RSS standard(s). Operation is subject to the following two conditions: 1) this device may not cause interference, and 2) this device must accept any interference, including interference that may cause undesired operation of the device.

Cet appareil est conforme avec Industrie Canada RSS standard exemptes de licence(s). Son fonctionnement est soumis aux deux conditions suivantes: 1) ce dispositif ne peut causer des interférences, et 2) cet appareil doit accepter toute interférence, y compris les interférences qui peuvent causer un mauvais fonctionnement du dispositif.

Notice for Europe

The EU Declaration of Conformity can be found on EntrustDatacard.com

WARNING: This is a class A product. This equipment is compliant with class A of either CISPR32 or CISPR22. In a domestic/residential environment this equipment may cause radio interference, in which case the user may be required to take adequate measures.

WEEE: The model RX10 retransfer printer uses a lithium coin cell battery. Refer to the service manual for battery removal instructions.

Notice for Australia

This is a Class A product. In a domestic environment this product may cause radio interference, in which case the user may be required to take adequate measures.

Notice for China (Simplified Chinese)

警告

此为 A 级产品，在生活环境中，该产品可能会造成无线电干扰。在这种情况下，可能需要用户对干扰采取切实可行的措施。

Notice for Taiwan (Traditional Chinese)

警告使用者：
這是甲類的資訊產品，在居住的環境中使用時，可能會造成射頻干擾，在這種情況下，使用者會被要求採用某些適當的對策。

Notice for Japan

Japanese Voluntary Control Council for Interference (VCCI) class A statement

この装置は、クラス A 情報技術装置です。この装置を家庭環境で使用すると電波妨害を引き起こすことがあります。この場合には使用者が適切な対策を講ずるよう要求されることがあります。

VCCI-A

Korea Communications Commission (KCC) statement

이 기기는 업무용(A급)으로 전자파적합기기로서 판매자 또는 사용자는 이 점을 주의하시기 바라며, 가정외의 지역에서 사용하는 것을 목적으로 합니다.

California Proposition 65 Compliance

WARNING: This product contains chemicals, including lead, known to the State of California to cause cancer, and birth defects or other reproductive harm. *Wash hands after handling.*

Entrust Datacard believes that its products are not harmful when used as designed. However, the above warning is made in compliance with the State of California Safe Drinking Water and Toxic Enforcement Act of 1986, which requires warning labels on products that may contain elements that the State of California considers harmful.

California Lithium Perchlorate Warning

Perchlorate Material - special handling may apply. See www.dtsc.ca.gov/hazardouswaste/perchlorate.

This notice is required by California Code of Regulations, Title 22, Division 4.5, Chapter 33: Best Management Practices for Perchlorate Materials. This product/part includes a battery that contains Perchlorate material.

Revision Log

CD800 Card Printer Installation and Administrator's Guide

Revision	Date	Description of Changes
A	March 2014	First release of this document (formerly Part No. 527249-001). Updated for CLM laminator and XPS Card Printer Driver 5.0.
B	February 2015	Updated for XPS Card Printer Driver 6.0; added IPv6 information
C	May 2015	Updated printer unpacking instructions.
D	November 2015	Updated for XPS Card Printer Driver 6.2 and new firmware functionality
E	January 2017	General updates



Contents

Chapter 1: Installation	1
PC Requirements	1
Ethernet Requirements	2
USB Requirements	2
Electrical Requirements	2
Site Requirements	3
Printer Dimensions	4
Single-Hopper Printer	4
Printer with Optional Multi-Hopper	4
Clearance Requirements	5
Single-Hopper Printer	5
Printer with Optional Multi-Hopper	5
Secure Printing Requirements	6
Set Up the Printer	6
Prepare the Printer	7
Remove Packing Material From the Printer	7
Load Cards	9
Load the Print Ribbon	10
Load the Cleaning Sleeve	11
Install the Ribbon Cartridge	11
Install Optional Equipment	12
Install a Large Output Hopper	12
Install the 200-Card Input Hopper	14
Install the Optional Cable Lock	15
Connect the Printer to a Computer	15
Connect Using a USB Cable	15
Connect Using a Network Cable	16
Plug in and Power On the Printer	16
Use the Front Panel	17
Configure the Printer	18
Use IPv4 Addressing	18
Set a Static IPv4 Address (Optional)	18
Use IPv6 Addressing	21
Enable IPv6	21
Set a Manual IPv6 Address (Optional)	23
Test the IP Address Using a Local Network	25
Use the Card Printer Driver	27
Use OpenCard Data Format	27

Chapter 2: Elements of Card Design	29
Basic Card Design	29
Printing Design	30
Color Printing	30
Full-Panel Ribbon	30
Short-Panel Ribbon	31
Split-Ribbon Color Printing	31
Manage Color	31
Print Text in Color	31
Print Graphics in Color	32
Monochrome Printing	32
Monochrome Printing with Full-Color Ribbon	32
Monochrome Ribbon	33
Ribbon Saver	33
Print Text in Monochrome	33
Print Bar Codes	34
Bar Code Guidelines	34
Test Bar Codes	35
Card Design Changes That Affect Bar Codes	36
Print Bar Codes With the Card Printer Driver	36
Apply Topcoat	37
Non-Printing Areas	37
Standard Magnetic Stripe Non-Printing Area	38
Standard Smart Card Non-Printing Area	38
Custom Non-Printing Areas	38
Card Layout	39
Margins	39
Backgrounds	40
Image Placement	40
Magnetic Stripe Design	41
Magnetic Stripe Data Formats	41
Three-Track Option (ISO/IAT)	41
Single-Track Option (JIS)	42
Magnetic Stripe Coercivity	43
Smart Card Design	43
Smart Card Processing Requirements	43
Smart Card Codes on the Printer Label	44
Single-Wire Smart Card	45
Settings for Card Design in Printer Manager	45

- Chapter 3: Printer Manager 47**
- Printer Manager 47**
 - Printer Manager User Access Levels 48
 - WebUser 48
 - WebAdmin 48
 - WebService 48
 - Access Printer Manager 48
 - Printer Manager Settings 51
 - Print a Printer Manager Page 51
- Use Printer Manager 51**
 - Status Menu 52
 - Printer Setting Menu 54
 - Communication 56
 - ActivityLog 59
 - Behavior 61
 - VitalProductData 63
 - FrontPanel 64
 - Print 65
 - Pick 71
 - Transport 71
 - Flipper 71
 - MagStripeGeneral 72
 - MagStripeCustomTrack 1-3 74
 - Laminator 76
 - LaminateType 83
 - Update Password 86
 - Set Job Queue State 87
 - TroubleShooting Menu 88
 - Test Card 89
 - Activity Log 92
 - Reset Log 92
 - Print Request Log 92
 - Reset Counters 92
 - Printer Reset 92
 - Personalization Tools Menu 93
 - Managed Items 93
 - Add Card Stock 93
 - Maintenance Menu 94
 - Cleaning 94
 - Updates 96
 - Log Out Menu 96

Chapter 4: Supplies and Parts	97
Print Ribbon	98
Color Print Ribbon	98
Full-Panel Color Print Ribbon	98
Short-Panel Color Print Ribbon	98
Color Print Ribbon Kits	99
Monochrome Print Ribbon	99
Monochrome Print Ribbon Kits	100
Ribbon Saver	100
Print Ribbon Storage Guidelines	101
Laminator Supplies	102
Topcoat and Patch Overlays	102
Overlay Storage Guidelines	104
Cards	105
Card Size	105
Card Material	105
Pre-Punched Cards	105
New Cards for Color Printing	105
Adhesive-Backed Cards	106
Card Quality Guidelines	106
Card Surface	106
Card Handling	106
Card Storage	107
Cleaning Supplies	107
Replacement Parts	108
Printhead Cartridge	108
Print Ribbon Cartridge	108
Cleaning Roller Spindle	108
Laminator Cartridges	108
Impresser Die	108
Optional Equipment	109
Large Output Hopper	109
200-Card Input Hopper	109
Cable Lock	109
Cables and Power Supplies	110
Data Cables	110
USB Cable	110
Network Cable	110
USB Smart Card Cable	110
Power Supplies	110
Power Cords	111

Appendix A: CLM Laminator	A-1
About the Laminator System	A-1
Site Requirements	A-2
System Dimensions	A-2
Clearance Requirements	A-3
Electrical Requirements	A-3
Unpack the System	A-4
Bolt-Down Option	A-5
Prepare the Printer	A-7
Remove, Replace, or Modify the Reject Tray	A-7
CD800 Printers Without Locks	A-7
CD800 Printers With Locks	A-7
Remove the Interconnect Port Tab	A-8
Remove the Mounting Lock Cover Tab	A-9
Replace the Output Hopper	A-10
Install Vent Covers	A-10
Assemble the Printer and Laminator	A-11
Connect the Power Cords	A-12
Connect the System to a PC	A-13
Connect a USB Cable	A-13
Connect a Network Cable	A-13
Load Laminator Overlay Material	A-14
Power On the System	A-16
Print a Test Card	A-16
Use the Card Printer Driver	A-16
Use the Printer LCD Panel	A-17
Use Printer Manager	A-18
Verify the Test Card	A-20

Chapter 1: Installation



This chapter describes system requirements and provides setup instructions for the Datacard® CD800™ Card Printer.

Your installation may have additional requirements for a card production environment. Consult your system administrator to determine the optimum location for card production.



For Card Printer Driver installation troubleshooting and card production troubleshooting information, refer to your printer's *Driver Guide* and *User's Guide*.

PC Requirements

Use a PC that meets or exceeds the following:

- A 32- or 64-bit processor, running at 2 GHz or faster
- 4 GB or more memory (RAM) and at least 1 GB free space on the hard drive
- One of the following operating systems:
 - Windows 10, 32- or 64-bit
 - Windows 8.1, 32- or 64-bit
 - Windows 7, 32- or 64-bit
 - Windows Server 2012, R2, 64-bit
 - Windows Server 2008, 64-bit
- USB 2.0 port or Ethernet network connection. The printer can use only one connection type.
- ID software or other card production software to capture and organize the data to print on each card

Ethernet Requirements

You can connect many network printers to one PC. The maximum number of printers depends on the capacity of the network to deliver data to the printer.

The following components are required to install a printer on a network:

- An Ethernet network that uses the TCP/IP protocol and can run at 100 megabits per second, also called 100base-T. Printers also support 10base-T.
- An Ethernet cable to connect the printer to the network. An Ethernet cable is not supplied with the printer.
- A PC that meets the “[PC Requirements](#)” described on [page 1](#), and is connected to, and communicating with, the network.

USB Requirements

You can connect up to eight card printers to a PC using USB cables.

To install a printer using a USB connection, the following components are required:

- A high-speed USB port. USB 2.0 is required.
- A USB cable to connect the printer to the PC. A USB cable is supplied with the printer.
- A PC that meets the “[PC Requirements](#)” described on [page 1](#).

If you need to connect two card printers to a PC with one USB port, use a single, independently powered USB hub to which you can connect both printers.

Electrical Requirements

The power supply detects the input voltage and works within the range stated.

Printer Model	Electrical Requirements	
	Input	Output
CD800	110-240V/50-60 Hz/1.5Amp	24V/3.0Amp/72W
CD800 with optional laminator	Refer to Appendix A: "CLM Laminator" .	

Site Requirements

Set up and use the printer in an environment that meets the following requirements.

- Place the printer in an environment with temperatures ranging from 60° to 95°F (15° to 35°C).
- Use a single-phase, 3-wire, grounded receptacle.
- Place the printer and its supplies in a clean office environment, keeping paper and foreign materials off of the equipment.
- Place the printer in a location that provides the following:
 - A sturdy, level surface. Avoid unstable locations.
 - A surface that allows easy user access. Refer to [“Printer Dimensions”](#) on [page 4](#) for more information.
 - Enough space to open all printer doors and to access power cords and data cables. Refer to [“Clearance Requirements”](#) on [page 5](#).
 - Enough space around the printer to allow for ventilation.
- Place the printer away from direct sunlight.
- Do not place the printer near heating ducts, fans, or other air vents.
- Do not use the printer for purposes other than the intended use.

Printer Dimensions

The external printer dimensions are shown in the following illustrations.

Single-Hopper Printer

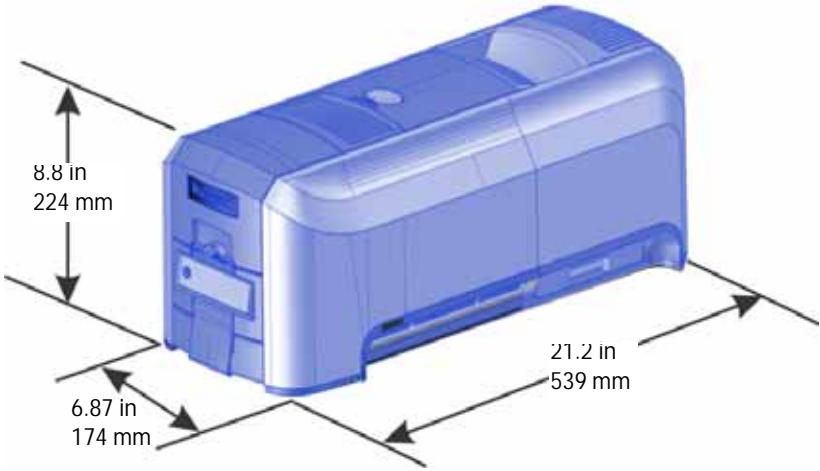

Printer with Optional Multi-Hopper

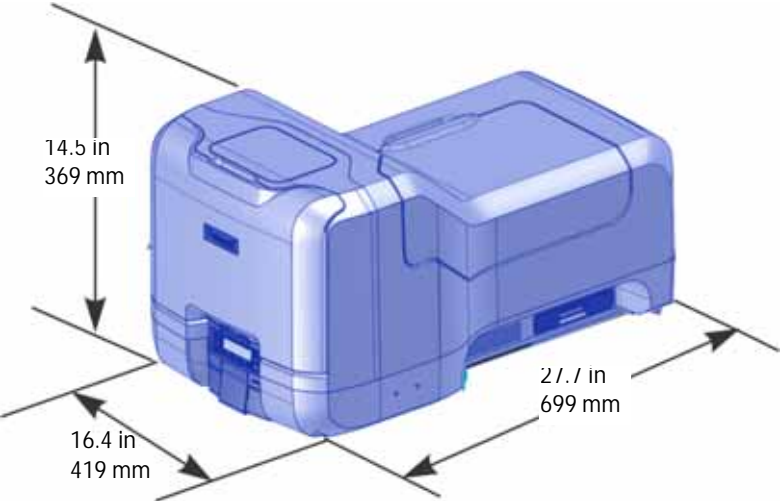

Clearance Requirements

The following measurements show the printer dimensions when the input hopper and printer covers are open.



We recommend that you provide a minimum of 3 inches (76.2 mm) of additional clearance around the printer to maintain access to the power cord and data cables, to load and remove cards and supplies, and to provide ventilation.

Single-Hopper Printer

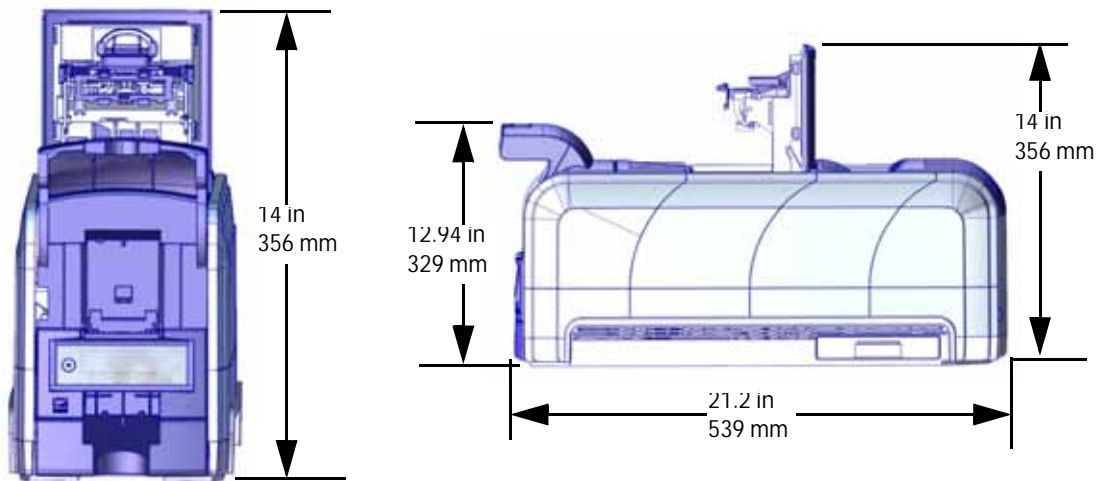

Options such as a large output hopper and 200-card input hopper add height to the printer. Additional clearance is required when using these options.

Refer to [Appendix A: "CLM Laminator"](#) for site information for the CD800 card printer with the optional laminator.

Printer with Optional Multi-Hopper

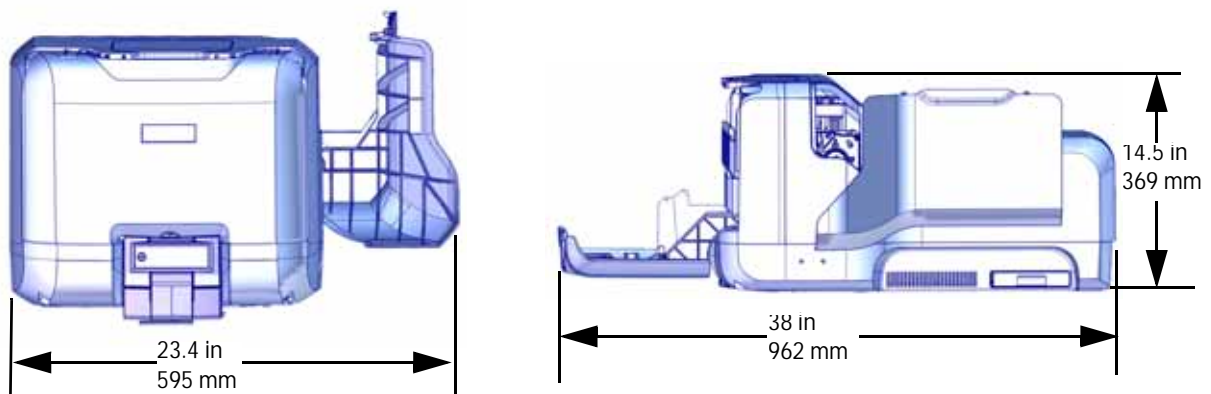

Secure Printing Requirements

Secure printing consists of encrypting print commands and card data and transmitting the information securely from the PC to the printer. Printers are shipped with all communication protocols (secure and non-secure) enabled. Refer to *"Behavior"* on [page 61](#) for more information about using the Printer Manager web service to specify printer security settings.

If you use the Card Printer Driver, make sure that the secure printing protocol (DPCL2Secure) is enabled and that the DPCL2 non-secure communication protocol is disabled. DPCL must remain enabled for the Card Printer Driver to function. For more information, refer to your printer's *Driver Guide*.

If your card production site requires secure printing, use the following:

- Datacard CD800 card printer with secure printing enabled
- A PC that meets the PC requirements cited earlier in this section
- An Ethernet or USB connection that meet the requirements
- A current browser, such as Internet Explorer, Firefox, or Chrome

Set Up the Printer

Use the information in the following sections to set up the printer to print cards.

- [Prepare the Printer on page 7](#)
- [Install Optional Equipment on page 12](#)
- [Connect the Printer to a Computer on page 15](#)
- [Plug in and Power On the Printer on page 16](#)
- [Configure the Printer on page 18](#)
- [Use the Card Printer Driver on page 27](#) or [Use OpenCard Data Format on page 27](#)

Prepare the Printer

To prepare the printer to print cards, remove any packing material, load blank card stock into the input hopper, and load the print ribbon and a cleaning sleeve onto the print cartridge.

Remove Packing Material From the Printer

 Required only on printers with the optional multi-hopper.

1. Remove the printer from its shipping carton.

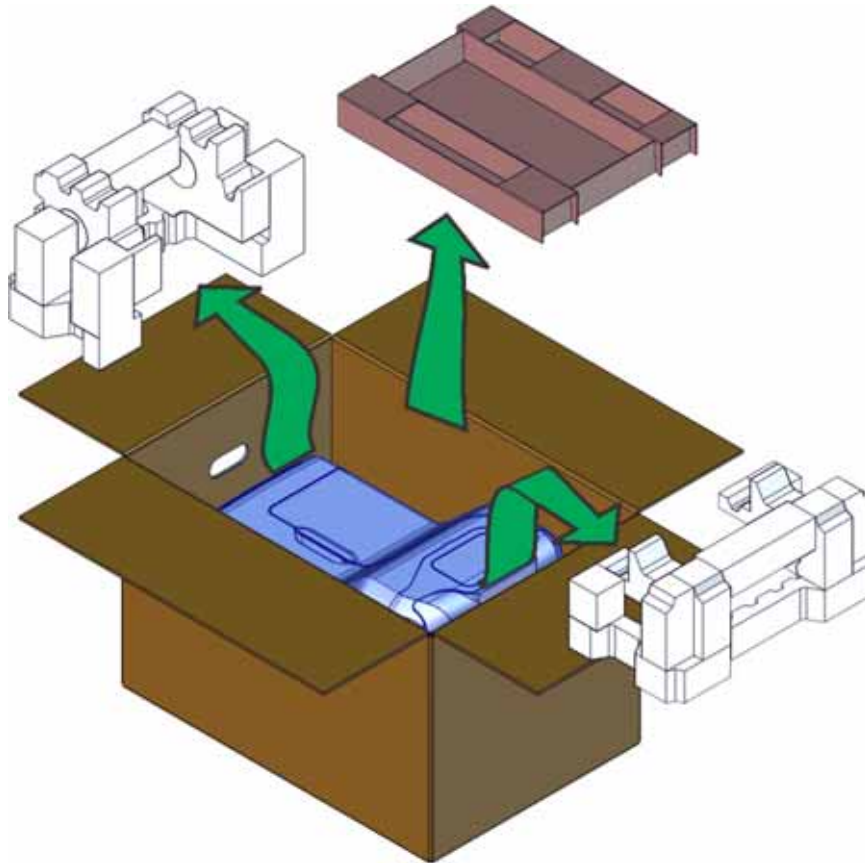

 Save the shipping cartons and packing materials. They are required if you need to store, move, or return the system for service.

2. Unlock the printer and open the printer supplies access door and the multi-hopper cover.
3. Remove the packing material inserted behind the multi-hopper and inside the cover.

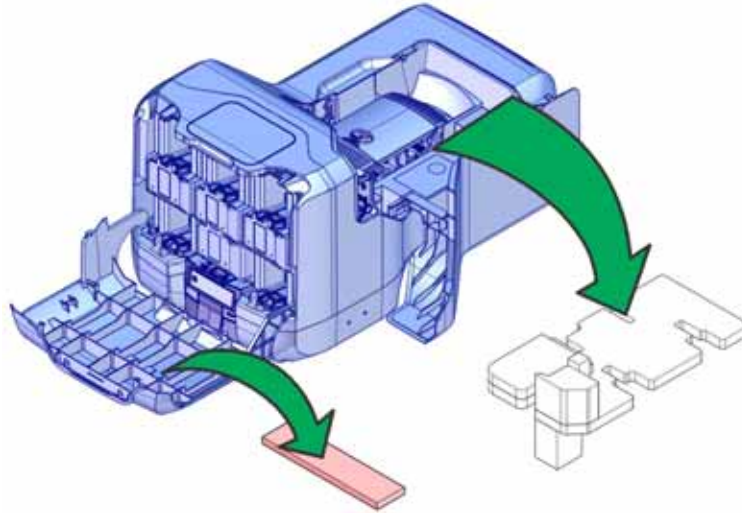

4. Close the multi-hopper cover and the printer supplies access door.

Load Cards

If you plan to insert cards into the printer manually, skip this step and keep a supply of blank cards near the printer.

- Cards can stick together. Slide or fan the cards to separate the edges before placing them in the input hopper. Handle cards by their edges only.
- Insert ISO magnetic stripe cards with the stripe (back side) facing down and to the right.
- Insert smart cards with the smart card chip facing up and toward the back of the hopper.

 A diagram inside the input hopper shows the correct orientation for each type of card.

Single Hopper

1. Unlock the printer, if necessary, and open the input hopper.
2. Load the cards into the input hopper.
3. Close the input hopper and lock the printer, if necessary.

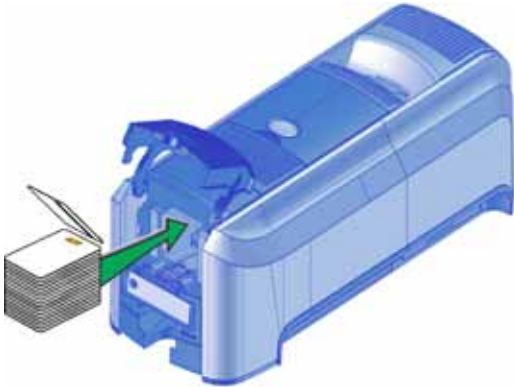

Optional Multi-Hopper

1. Unlock the printer and open the multi-hopper.
2. Load the cards into the hoppers.
The input hoppers are labeled H1 through H6. You can load up to 100 cards into each hopper.
3. Close the multi-hopper and lock the printer when you finish loading cards.

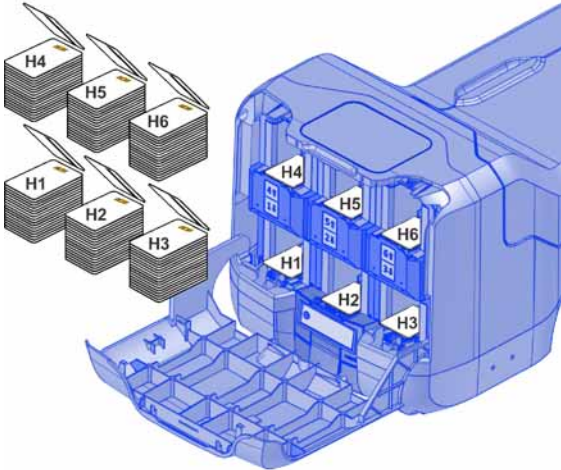

Load the Print Ribbon

Load the ribbon when you install the printer and when the ribbon runs out.

1. Unlock the printer, if necessary, and open the printer supplies access door on the optional multi-hopper.
2. Open the printer cover.

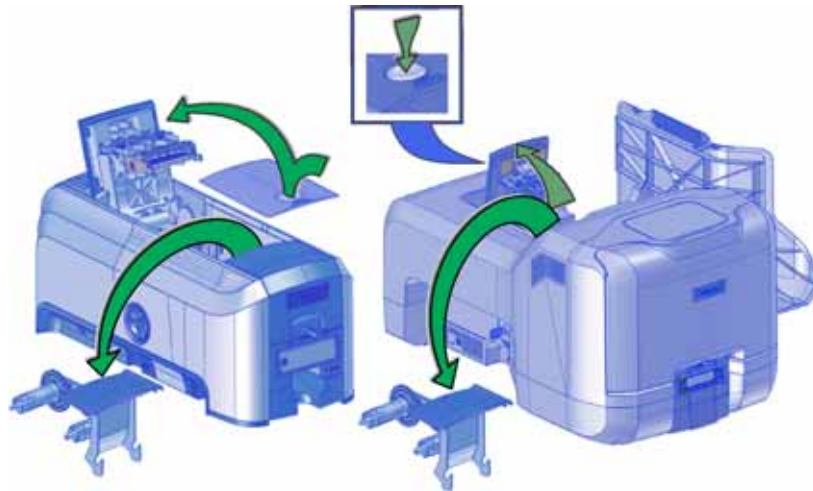

3. Remove the print ribbon cartridge.
4. Load a full roll of print ribbon (the blue spool) onto the spindle closest to the cartridge handle until it clicks into place.
5. Place the silver take-up spool on the spindle with the black gear until it clicks into place.
6. Wind the take-up spool counterclockwise one full turn.

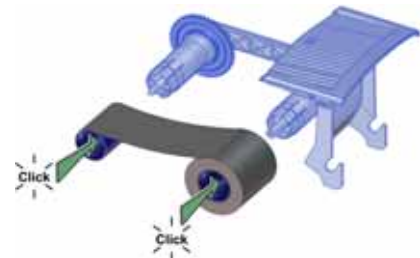

Load the Cleaning Sleeve

The cleaning sleeve removes debris from the card before printing begins. It fits on a spindle that mounts on the print ribbon cartridge. The printer ships with the cleaning roller spindle in the accessory box.

1. Locate the cleaning roller spindle and slide the spindle into the continuous cleaning sleeve (a).
2. Place the spindle with cleaning sleeve onto the ribbon cartridge (b).
3. Remove the protective wrapper from the cleaning sleeve (c).

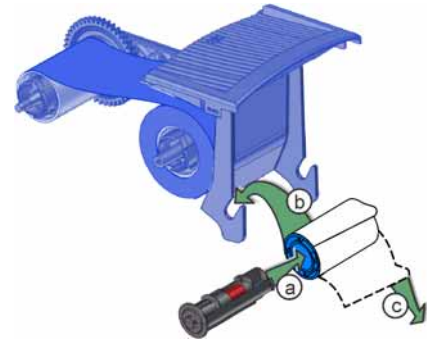

Load a new cleaning sleeve with each new roll of print ribbon, if you notice debris on the printed cards, or if the cleaning sleeve is no longer sticky.

Install the Ribbon Cartridge

Install the assembled print ribbon cartridge into the printer.

1. Open the printer cover.
2. Hold the print ribbon cartridge by the handle and lower it into the printer with the handle toward the front of the printer.

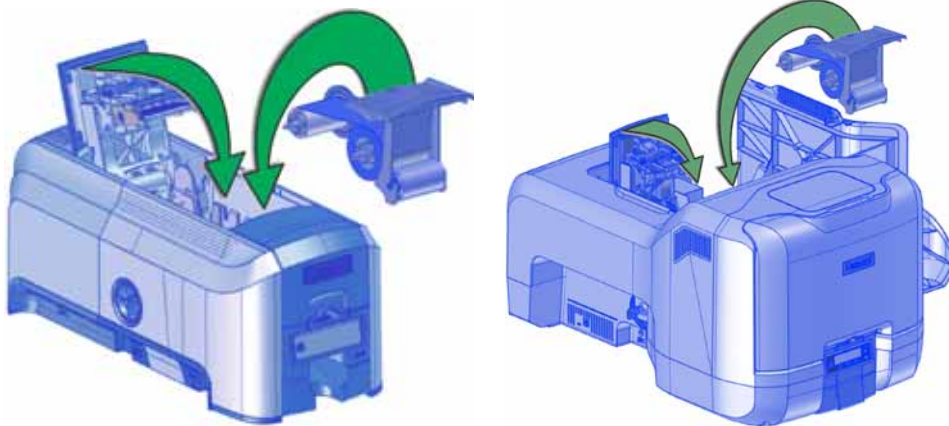

3. Make sure that the ribbon cartridge is positioned correctly in the guides.
4. Close the printer cover. Press down on the ridges on the front of the cover to make sure that it latches completely on both sides.
5. Close the supplies access door on the optional multi-hopper. Lock the printer, if necessary.

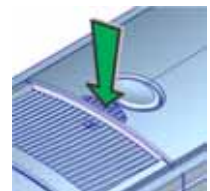

Install Optional Equipment

You can install additional equipment on the printer depending on your requirements.

Install a Large Output Hopper

The standard output hopper included with the printer holds about 25 0.030 in. (0.762 mm) cards. The printer also can be used with an optional large output hopper that holds up to 100 cards.

 The large output hopper can be installed only on single-hopper printers.

The large output hopper kit includes two base sections and the large output hopper. The two base sections are identical, with hooks (marked by green circles) that attach to the bottom of the printer. To assemble the base, arrange the base sections back to back, as shown.

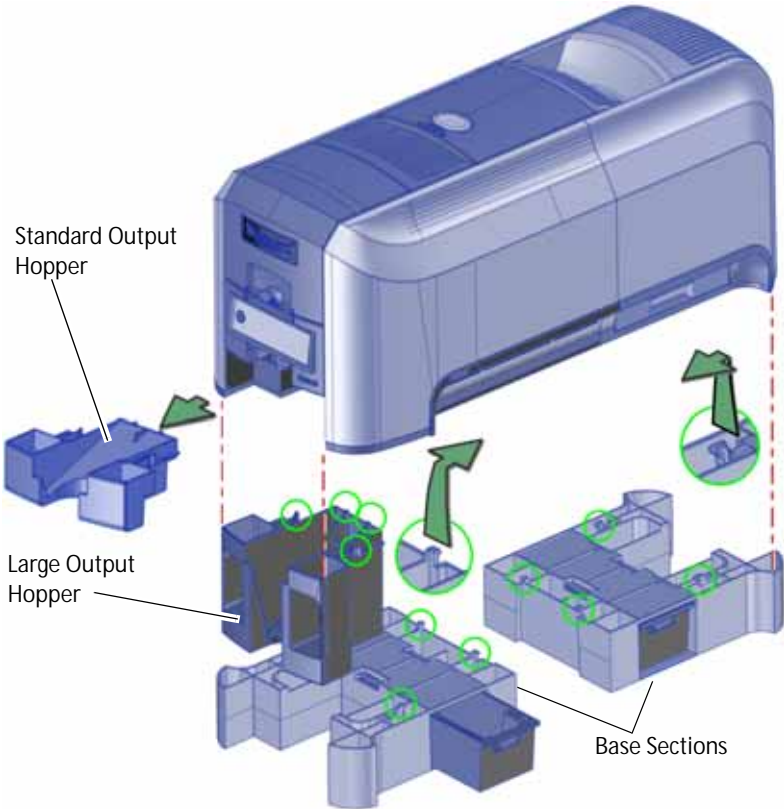

You can remove the standard hopper and attach the large output hopper without using tools.

Do the following to attach the printer to the bases, and to install the larger output hopper. You also can refer to the instructions shipped with the large output hopper kit.

1. Position one base section with the open end facing the back of the printer.
2. Lift the printer over the base section.
3. Align the tabs in the base with the slots in the bottom of the printer.
4. Push up to insert the four tabs in the slots, and then push the base forward to lock it to the printer.
5. Position the other base section with the opening facing the front of the printer.
6. Push up to insert the four tabs in the slots and then push the base back to lock it to the printer.
7. Remove the 25-card output hopper from the printer. Slide it out, similar to a drawer.
8. Slide the 100-card output hopper into the assembled base and printer. Make sure that the tabs (shown in circles in the illustration) secure the hopper to the printer.

HINTS & TIPS

- The base sections contain drawers, useful for holding cards, cleaning swabs, or other frequently used items. The drawers can be opened from either the left or right side of the printer.
- The base and large output hopper remain attached when the printer is moved or carried.



If you install the 100-card output hopper, change the Printer Manager **Printer Setting > Transport EjectHopperSpeed** setting to **ehs_Extended**. This allows completed cards to stack properly in the larger output hopper. Refer to ["Transport"](#) on [page 71](#) for complete information.

Install the 200-Card Input Hopper

The standard input hopper of a single hopper printer can hold about 100 0.030 in. (0.762 mm) cards. The printer can be upgraded to use a 200-card input hopper.

The 200-card input hopper kit includes the larger hopper with an attached cover. The standard hopper can be removed, and the 200-card hopper can be installed, without using tools. You also can refer to the instructions shipped with the 200-card input hopper kit.

1. Open the input hopper.
2. Press the release tab located on the back wall of the hopper while lifting the hopper up and off the printer.
3. Install the 200-card input hopper by aligning the tabs with the slots on the printer.
4. Push the hopper down until it clicks into place.
5. Load up to 200 cards in the hopper and close the hopper cover. Lock the printer, if necessary. The printer is ready to print cards.

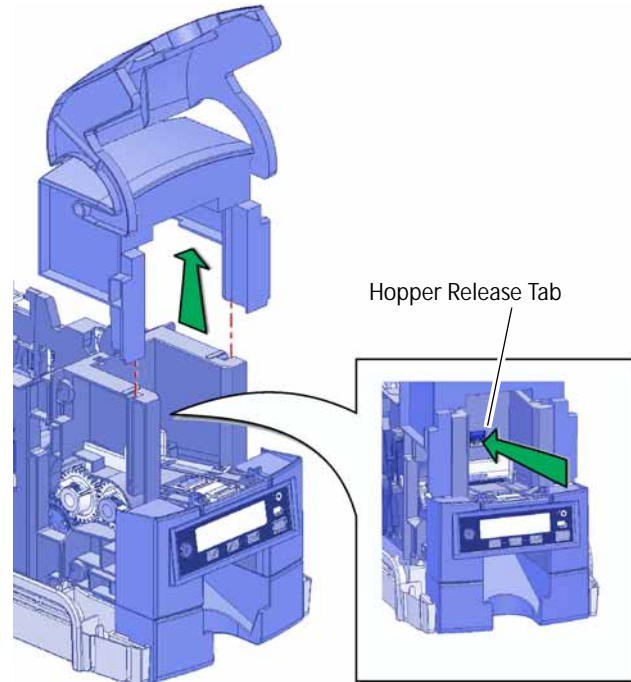

Install the Optional Cable Lock

The cable lock is a user-installed feature that does not require special tools to install. The package contains a cable lock, instructions, and a metal security plate. The security plate is installed in the printer and is designed to accommodate the T-bar of the cable lock.

 The cable lock is available with either a key or combination lock.

1. Prepare the printer by installing the metal security plate:
 - a. Tip the printer on its right side.
 - b. Locate the security plate receptacle on the underside of the printer toward the back left side.
 - c. Insert the security plate into the receptacle with the open end toward the printer.
 - d. Insert the T-bar of the cable lock through the printer opening into the security plate.
2. Follow the instructions included with the lock to complete the installation.

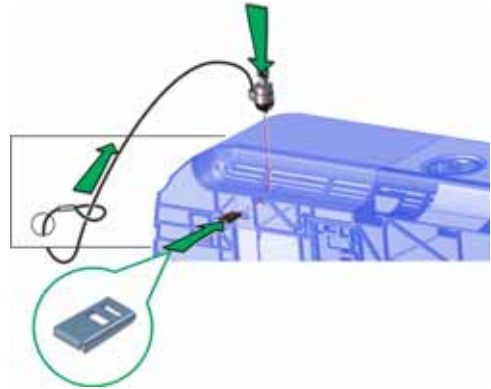

Connect the Printer to a Computer

You can connect the printer to a Windows-based PC using either a USB cable, or through a network using an Ethernet cable (the Ethernet cable is not supplied with the system).

Connect Using a USB Cable

 Do not connect the USB cable to the computer until you are prompted during installation of the Card Printer Driver. Refer to the printer's *Driver Guide* to set up the Card Printer Driver to work with the printer.

1. Connect one end of the USB cable to the USB port of the printer.
2. Connect the other end to a USB port on the PC when you are prompted during installation of the Card Printer Driver.

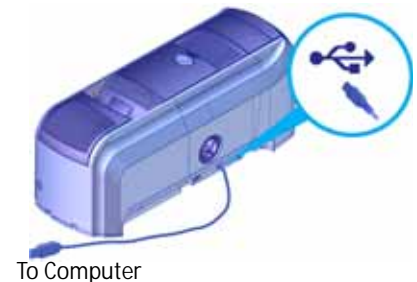

Connect Using a Network Cable

1. Connect one end of the Ethernet cable to the network connection port on the printer.
2. Connect the other end to a network port.
3. If you use the Card Printer Driver, refer to the printer's *Driver Guide* to set up the driver to work with the printer.



Plug in and Power On the Printer

Plug in the printer power cords and connect the printer to the facility power source.

Single Hopper

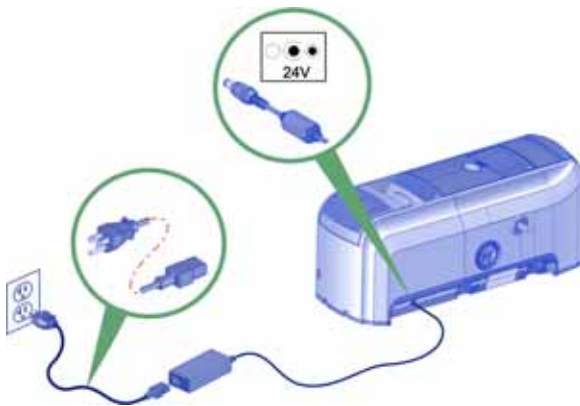

Optional Multi-Hopper

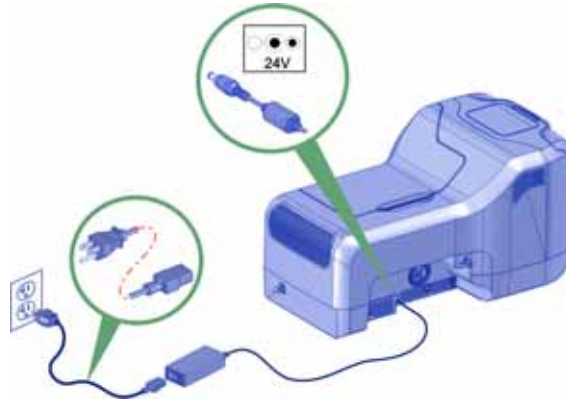

Press the POWER button on the front panel to power on the printer. The front panel LCD displays **Ready** when the printer is ready to print.

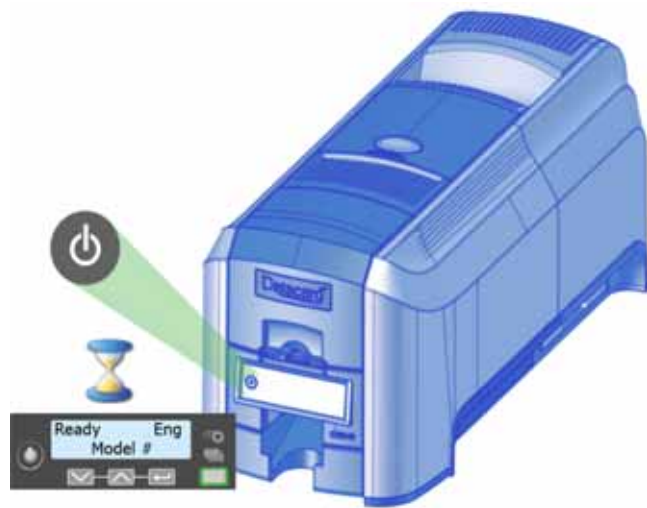

Use the Front Panel

The front panel of the printer provides the controls you need to operate the system. Refer to the printer's *User's Guide* for complete information about using the front panel.

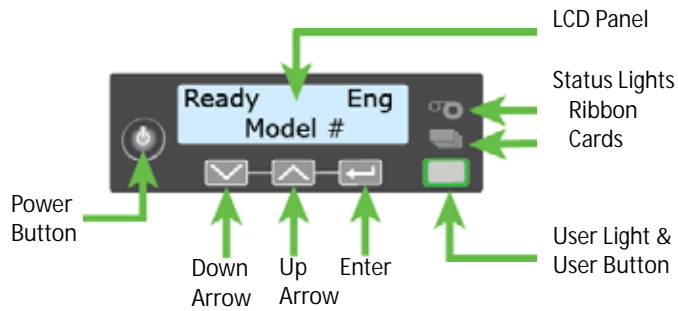

Configure the Printer

The printer supports both IPv4 and IPv6 addressing. If your network environment uses IPv6, you may be required to use the LCD **Configuration** menu to enable the IPv6 settings that manage the printer communication over an Ethernet network. You do not need to make any configuration changes to use IPv4.



You also can use Printer Manager to change the communication method and define printer address information. Refer to [“Communication”](#) on [page 56](#).

Use IPv4 Addressing

When you use IPv4, the printer can use either of the following network communication methods:

- **DHCP (Dynamic Host Configuration Protocol)**—The network automatically assigns the IP address to the printer. The IP address of a printer that uses DHCP can change if the printer is powered off and back on.
- **Static IP**—You set the IP address, subnet mask, and gateway address, as provided by your network support personnel. A static IP address does not change when the printer is powered off. Some sites may require that the printer has the same IP address at all times. Refer to [“Set a Static IPv4 Address \(Optional\)”](#).

Set a Static IPv4 Address (Optional)

The default communications method is DHCP (Dynamic Host Configuration Protocol). If you need to assign a static IP address, you can use the front panel to change the address method and enter the address information.



You can set a static IP address on a printer even if it is not connected to the network. For example, a group may set up several printers in a central location before installing them at individual sites. You can test the IP address by setting up a local network. Refer to [“Test the IP Address Using a Local Network”](#) on [page 25](#) for more information.

1. Obtain the following values from your network support personnel. Make sure you receive all three values:
 - IP address
 - Subnet mask
 - Gateway address

2. Enter the menu system.
 - a. Press the USER button to suspend the printer.
 - b. Press ENTER to enter the menu system.
 - c. Press the down arrow until **Configuration** displays on line 2.
 - d. Press ENTER to enter the **Configuration** menu.
 - e. Press the down arrow to display **Network IPv4** on line 2.
 - f. Press ENTER to enter the **Network IPv4** menu. **DHCP/Static IP** displays on line 2.
3. Press ENTER to display the **DHCP/Static IP** menu. **Static IP** displays on line 2.

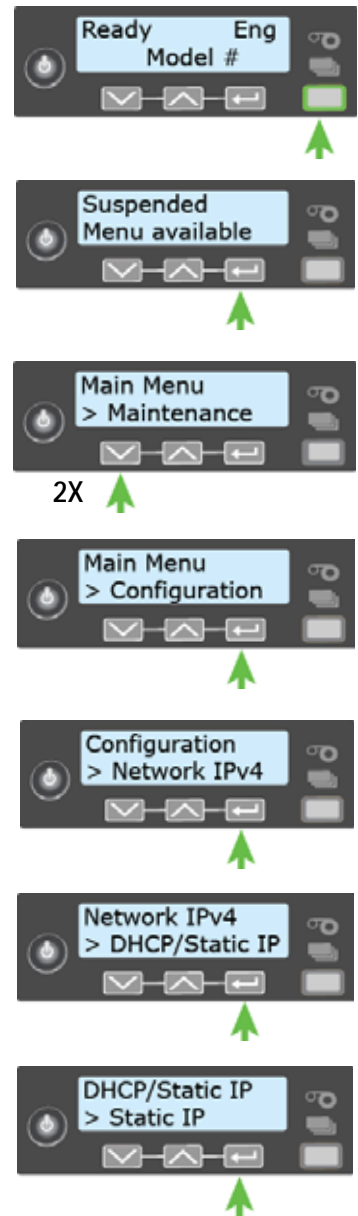

4. Set the static IP address, subnet mask, and gateway address.

a. Press ENTER to enter the **Static IP** menu. **IP Address** displays on line 2.



b. Press ENTER to set the static IP address.

The IP address has four sections, separated by periods. A cursor appears under the digit that will change.



- i. Use the arrow keys to change one digit at a time.
- ii. The address section shows three digits when it can be changed and the cursor is under the right-most digit. Press ENTER to navigate to the next section of the address.

iii. When all four sections are correct, press ENTER. **Subnet Mask** displays on line 2 of the LCD panel.

c. Repeat steps i through iii to enter the subnet mask and gateway address.

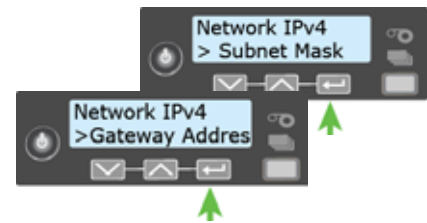

5. Press ENTER when you finish entering all the required address information. **Apply** displays on line 2.

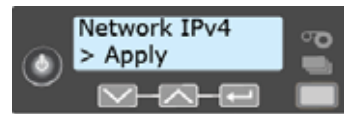

6. Press ENTER to apply your changes.

7. Press the down arrow key to scroll to **Exit** on line 2.

8. Press ENTER. Then, press the USER button to return the printer to **Ready**. The USER button glows green.

Use IPv6 Addressing

The expanded address space provided by IPv6 is becoming increasingly common in network environments. A printer on an IPv6 network can be configured to use one or more of the following methods, depending on how the network is set up:

- **Link Local IPv6 address:** The printer and PC clients are restricted to the same subnet. Link local is enabled automatically when IPv6 is enabled and offers the best security for your network.
- **DHCPv6:** A DHCPv6 server is externally configured to give out an IPv6 address.
- **Stateless Address AutoConfiguration (SLAAC):** One or more routers with IPv6 enabled on the subnet give out a subnet prefix that allows access to IP addresses.
- **Manual IPv6 Address:** The printer has a designated IPv6 address on a specified subnet. The address does not change without manual intervention. This is similar to an IPv4 static IP address.

To use IPv6 with the card printer, you need to connect to an IPv6 network and enable one or more address configuration methods. Link local, DHCPv6, and SLAAC automatically configure an address, but may require the necessary network support (DHCPv6 and routers). Refer to “[Enable IPv6](#)” on [page 21](#) for complete information about how to enable IPv6.



This *Guide* assumes that your IPv6 network is configured and that you have the information you need to set up the card printer. If you need information about your network configuration, contact your network administrator.

Enable IPv6

Use the front panel **Configuration** menu to enable the IPv6 method used by your network.



The following example illustrates enabling a manual IPv6 address.

1. Enter the menu system.
 - a. Press the USER button to suspend the printer.
 - b. Press ENTER to enter the menu system.

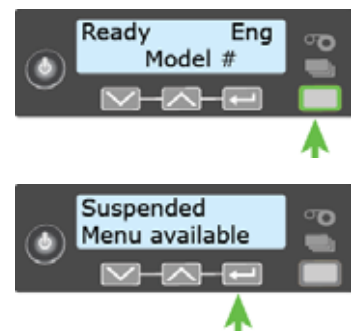

- c. Press the down arrow key until **Configuration** displays on line 2.



2X↑

- d. Press ENTER to enter the **Configuration** menu.



- e. Press the down arrow to display **Network IPv6** on line 2.

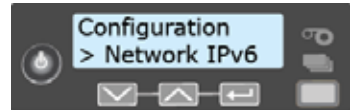

- f. Press ENTER to enter the **Network IPv6** menu.

2. Set the IP Mode.

The IP Mode determines whether the printer uses IPv4-only or both IPv4 and IPv6 addressing.

- a. Press ENTER to enter the **IP Mode** menu.

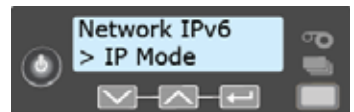

- b. Press the down arrow to display **DualStack** on line 2. Specifying DualStack allows the printer to use both IPv4 and IPv6 addresses.

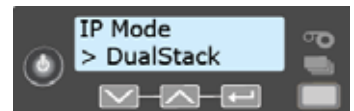



- c. Press ENTER to set the IP Mode.

 The IP Mode must be set to **DualStack** to allow any of the following settings to be used. If you want to use IPv4-only in the future, change the IP Mode to **IPv4**. The printer retains the IPv6 settings specified below, but they are not used. This allows you to return to IPv6 at a later time.

3. Press the down arrow until the type of addressing you want to enable displays on line 2.

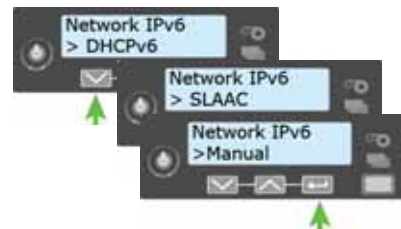
- DHCPv6
- SLAAC
- Manual



 The printer can have multiple IPv6 addresses, depending on your network environment. All of the IPv6 addresses can be used to access the printer.

4. Press ENTER to open the selected address menu.
5. Press the arrow keys to enable the IPv6 address method.
6. Press ENTER to confirm your selection.

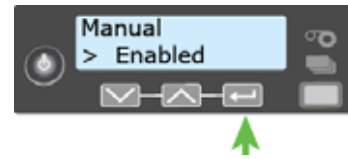

If you enabled DHCPv6 or SLAAC, the printer automatically obtains one or more IP addresses. If you want to enter a manual IP address, refer to [“Set a Manual IPv6 Address \(Optional\)”](#).

Set a Manual IPv6 Address (Optional)

If you want the printer to keep the same IPv6 address at all times, you can enter a manual address using the **Configuration** menu. (This is similar to setting a static IPv4 address.)



You also can enter the IPv6 address using Printer Manager. You must access Printer Manager using an IPv4 address before you can set the IPv6 address. The **Printer Setting > Communication** menu allows you to type the IPv6 address information instead of using the LCD panel. Refer to [“Communication”](#) on [page 56](#).

1. Obtain the following values from your network support personnel. Make sure you receive all values:
 - IPv6 address
 - IPv6 subnet prefix length
 - Gateway address
2. Make sure that the IPv6 manual address method is enabled. Refer to [“Enable IPv6”](#) on [page 21](#).

When you enable IPv6 manual addressing, **Manual Address** displays on line 2. Press ENTER to start entering the IP address.

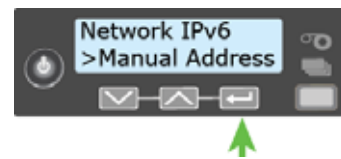

3. Enter the IPv6 address.

An IPv6 address is represented as eight groups of four hexadecimal digits separated by colons. The address requires 39 characters to display. Because the LCD is limited to 16 characters per line, the IPv6 address is spread across three screens of the LCD. A digit at the end of line 1 indicates which section of the address is being displayed.

A cursor appears under the digit that will change.

- a. Use the arrow keys to change each hexadecimal digit, from 0 to F.
- b. Press ENTER to move the cursor to the next digit.
- c. When the address section on the first screen is complete, press ENTER to display the next section of the address.

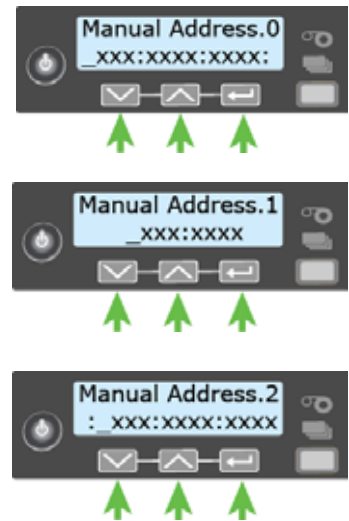

4. When all three sections are correct, press ENTER to save the address. **Prefix Length** displays on line 2.

5. Press ENTER to view or change the prefix length.

The prefix length indicates the boundary between the subnet to which the host is connected and the device ID in the IPv6 manual address. Press the up or down arrow to change the prefix length.

6. Press ENTER to save your changes and display **Gateway Address** on line 2.
7. Press ENTER to start entering the default gateway address.
 - a. Repeat [step 3](#), a through c, to enter the gateway address.
 - b. When all three screens are correct, press ENTER to save the gateway address.
8. Press the down arrow key until **Exit** displays on line 2.
9. Press ENTER. Then, press the USER button to return the printer to **Ready**. The USER button glows green.

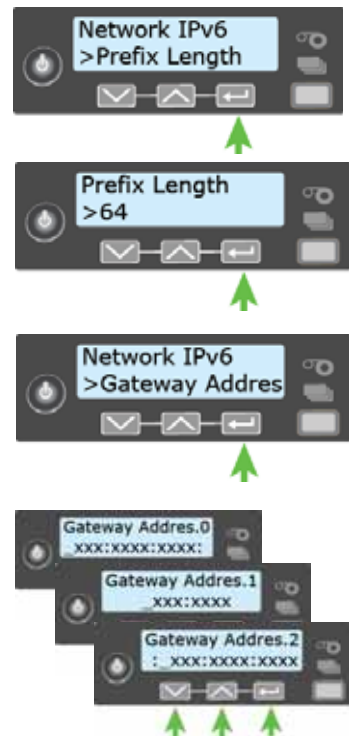

Test the IP Address Using a Local Network

You can set up a local network consisting of the printer and a computer. This allows you to test whether the printer and computer can communicate using the IP address, and to test that the printer is functioning correctly. You might use this procedure if you set up multiple printers in a central location before installing them at individual sites.



- This procedure is optional.
- You also can use this procedure to connect a printer to a computer using an Ethernet cable if the USB port on the printer is unavailable or is not working properly.

The following procedure demonstrates testing a static IPv4 address.

1. Connect the printer directly to a computer using an Ethernet cable.
2. Open the Windows Network and Sharing Center and select **Local Area Connection**.
3. Click **Properties** on the Local Area Connection Status menu.

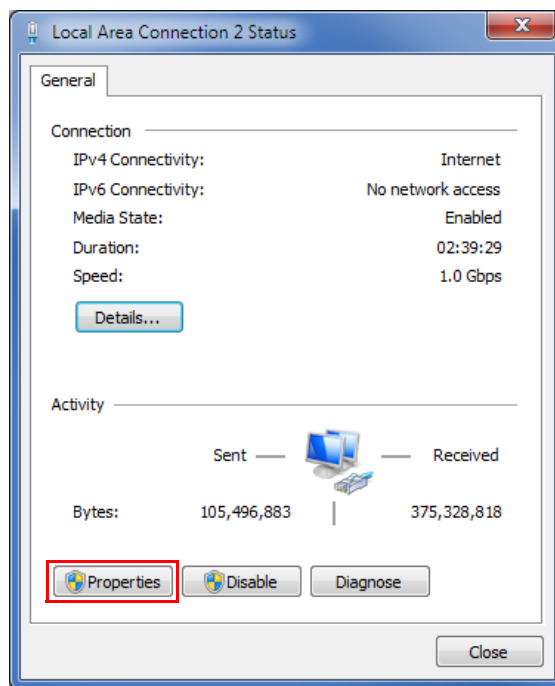

4. On the Local Area Connection Properties dialog box, select **Internet Protocol Version 4 (TCP/IPv4)**. Click **Properties**.

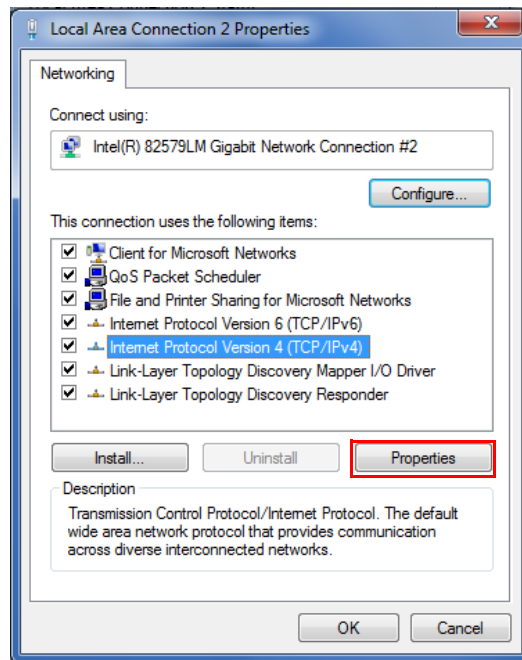

5. Use the Properties dialog box to enter the IP address information. Select **Use the following IP address**.

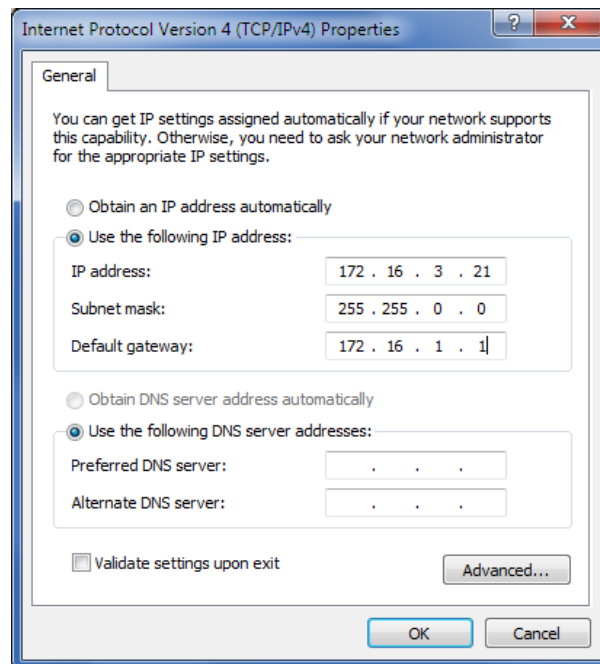

- a. In the IP address field, enter the value for the static IP address that you set on the front panel of the printer. Give the last section of the IP address a value that is at least plus one from the address on the printer front panel.



For example, if the IP address that is set on the front panel of the printer is 172.17.1.113, enter the address as 172.17.1.114 on the computer.

- b. In the Subnet mask and Default gateway fields, enter the subnet mask and default gateway address that you entered on the front panel of the printer.
 - c. When you finish entering values for IP address, subnet mask, and gateway address, click **OK**.
6. Test the printer to verify that it can communicate with the computer using the IP address. Run several test cards to make sure that the printer is functioning properly.
 7. Power off the printer and disconnect it from the computer.
 8. Connect the printer to the network and power it on.
 9. Log in to Printer Manager and configure the printer based on your requirements. Refer to [Chapter 3: "Printer Manager"](#) for complete information about using Printer Manager.

Use the Card Printer Driver

The XPS Card Printer Driver uses Microsoft XPS print technology to support printing from currently available Microsoft Windows applications.

To use the CD800 card printer with the optional Card Printer Driver, you must install and configure the driver. Refer to the printer's *Driver Guide* for complete information about installing and using the Card Printer Driver.

Use OpenCard Data Format

The CD800 card printer can print cards sent to the printer using the OpenCard data format. The OpenCard option must be enabled at the factory. For more information about setting up and using the OpenCard option, refer to the *SD/CD Series Card Printers OpenCard Data Format Guide*.



The OpenCard Data Format option is not supported by the Card Printer Driver. When OpenCard is enabled, the Card Printer Driver cannot be used to communicate with the printer.



Chapter 2: Elements of Card Design

2

Card design is the name given to the combined features of the processed cards. An organization can have multiple card designs.

This chapter provides the following information about card design:

- [Basic Card Design](#)
- [Printing Design on page 30](#)
- [Magnetic Stripe Design on page 41](#)
- [Smart Card Design on page 43](#)
- [Settings for Card Design in Printer Manager on page 45](#)

Basic Card Design

Card design includes:

- Color and monochrome printing.
- The various types of data, such as name, account number, and special features such as a magnetic stripe or smart card chip.
- The layout of the data.
- Optional lamination for enhanced wear protection and security (laminating systems only).
- Optional ultraviolet (UV) printing for enhanced security.



Printing Design

Printing design includes color and monochrome printing, bar code printing, non-printing areas, and card layout.

Color Printing

Color print ribbon is available in full-panel and short-panel styles.

Full-Panel Ribbon

Full-panel color printing uses a print ribbon with three color panels: Y (yellow), M (magenta), and C (cyan). The ribbon also includes a K (black) panel and a T (topcoat) panel. The printer applies the YMC color panels to the card first, prints black components using the K panel, and then applies the T (topcoat) to protect the color image from damage.



Laminating printers support full-panel color print ribbons without a topcoat (T) panel. These include YMCK and YMCK-K ribbon. The topcoat or patch overlay applied by the laminators provides protection against wear and color fading, so the print ribbon topcoat panel is not needed for most overlay materials. However, DuraShield overlays require that the ribbon topcoat be applied first.

Full-panel color print ribbons with an ultraviolet (UV) fluorescent panel, YMCKFT and YMCKF-KT, also are available.



Laminating printers support YMCKF-KT ribbon, which allows front-side UV printing, and apply an overlay to protect the color printing.

The UV printing is undetectable under normal lighting and is meant to provide another form of security. Refer to your printer's *Driver Guide* or your card personalization software documentation for more information about setting up a card design that includes UV printing.

 The ribbon panel configuration that supports YMCKFT functionality can differ depending on your printer model.

Short-Panel Ribbon

Color print ribbon also is available in a short-panel option. The color area for short-panel ribbon is either 1.57 inches (40 mm) or 1.47 inches (37.5 mm), depending on the ribbon configuration. The ymc panels of short-panel ribbon are approximately half the length of a full card. (In this guide, “ymc” in lowercase, instead of “YMC,” refers to “short-panel” color panels.)

Short-panel ymcKT Ribbon



When you print with short-panel print ribbon, you define the location of the color area in the card design. Color printing begins when the software detects a color pixel and continues for the length of the ymc panels.

Split-Ribbon Color Printing

Split-ribbon color printing lets you use less ribbon to print cards in color. It is available only with the Card Printer Driver. Refer to your printer's *Driver Guide* for information about how to specify split-ribbon color printing and the split ribbon options available.

Split-ribbon color printing uses a single ribbon panel set from a full-color ribbon to print both sides of a card, rather than two or three panel sets. The ribbon can be a full-panel or short-panel color ribbon. The order in which the color, black, and topcoat sections of the panel set are used to print the card depends on the type of ribbon installed in the printer and the split-ribbon option selected on the printer's Printing Preferences window.



Most types of cards, including cards with magnetic stripes and smart cards, can be printed using split-ribbon printing. Options for color, monochrome, and topcoat are available when you use split-ribbon printing.

Manage Color

Color management is the process of making color on the PC monitor and printed card appear as similar as possible. For color management, the card printer uses the sRGB color standard (standard Red, Green, and Blue color space). You specify the color management system in Printer Manager. Refer to “Print” on [page 65](#) for more information.

Print Text in Color

The printer can print text in any color. Small characters are likely to be more readable if they are a sans-serif font formatted as black and printed with the black (K) panel. Refer to “Print Text in Monochrome” on [page 33](#). The printer supports 6-point or larger text.

Print Graphics in Color

The printer produces full-color images from most types of graphics. It can use BMP, JPEG, TIFF, and PNG file formats for photos and logos.

Vector graphics, such as WMF and SVG files, have components such as shapes with lines and fills. Components defined as black normally print with the K panel.

Because the printer uses the print ribbon panels in sequence (YMC first, then K), black images can print over color graphics. For the best appearance of color graphics, or to prevent backgrounds that are black from printing over colored images, use a color that appears black but is not, so that all parts of an image print with the YMC panels. For example, in the RGB color space, 0, 0, 0 is black (and prints with the K panel), but 0, 0, 5 is not black (and prints with the YMC panels).

Types of Color Images

Cards can include both color photos and color logos. The logo is usually the same on each card, and the photo is unique. Follow these guidelines to obtain the best results for printing both logos and photos.

1. Evaluate the color quality of the photos:
 - a. Adjust the image capture system to get the best quality photos; work with distance, lighting, and camera settings to obtain consistent, high-quality photos.
 - b. Evaluate the quality of printed photos after the image capture system is optimized.
2. Evaluate the other color areas of the card, such as text or logo:
 - a. Check your card production application for settings that can help improve the printed color of text.
 - b. Use an image editing application to adjust the color of a logo file for optimal printing.

Monochrome Printing

Monochrome printing prints cards using a single color. You can use a full-color ribbon or a monochrome ribbon that has only one color.

Monochrome Printing with Full-Color Ribbon

Full-color print ribbon includes a black panel. The black panel transfers to the card differently than the YMC panels. Text and bar codes are usually printed with the black panel. Full-color print ribbon also prints any monochrome or one-bit-per-pixel graphics using the K panel.

Full-panel YMCKT Ribbon



Monochrome Ribbon

Monochrome ribbon produces single-color cards. Monochrome ribbon can be any of the following:

- Alternating black and topcoat panels (KT or KTT ribbon)

The printer applies black and one or two topcoat panels on the same side of the card.

- Continuous black (K ribbon)
- A continuous color, for example, green or silver (also called a K ribbon). Refer to [“Monochrome Print Ribbon Kits”](#) on [page 100](#) for a list of available colors.

- Silver-Topcoat, Black (K)-Topcoat (ST-KT) and Gold-Topcoat, Black (K)-Topcoat (GT-KT), also referred to as MT-KT ribbons

These ribbons print the front side of the card using the monochrome color panel and the back side using the black (K) panel. Topcoat is applied to both the front and back of the card. If the printer does not support the ribbon type, only the K panel is used.

KT Ribbon



KTT Ribbon



Monochrome (K) Ribbon—Black



Monochrome Ribbon—Green



ST-KT Ribbon



GT-KT Ribbon



Ribbon Saver

Continuous monochrome printing with Datacard-certified ribbon uses the Ribbon Saver feature. With Ribbon Saver, the printer begins using ribbon at a location that corresponds to the leading edge of the card. The printer continues to spool ribbon for the length of the image but no farther. The printer leaves a small margin between each card to avoid image overlap.

Print Text in Monochrome

Printing text using a K panel can make text look crisp, because it uses only one panel for printing. Fine text is more readable when printed with more power. You set the power for the K panel using Printer Manager. Refer to [“Print”](#) on [page 65](#) for more information.

The font used also affects legibility. The printer reliably prints 6-point Arial font. Bold, sans-serif fonts are more readable after printing than serif fonts, or fonts with thin strokes, as shown at right. In the example, fonts that print well are shown toward the top of the card.



Print Bar Codes

Bar code design follows a set of standards based on the type of bar code produced. Bar codes contain a series of black lines (bars) separated by white areas (spaces). Each character of encoded data is represented by a set of bars and spaces. A bar code standard specifies the number and width of bars and spaces needed to encode a character. The standard also specifies the minimum size of the white area, or quiet zone, that surrounds the bar code.



Refer to [“Print Bar Codes With the Card Printer Driver”](#) on [page 36](#) for information about how to use the Card Printer Driver to improve the probability that a bar code prints using the K panel.

Bar Code Guidelines

Bar codes print more successfully when you observe the following guidelines. Follow the standards for the type of bar code you are printing.

Bar Code Placement

- Maintain the required quiet zone around the actual bar code, as shown in the illustration.
- Locate bar codes at least 0.25 inch (6.3 mm) from other printing and from the edge of the card.
- For best results, orient the card so that the bars are parallel to the long edges of the card, as shown. This orientation most accurately prints readable bar codes.

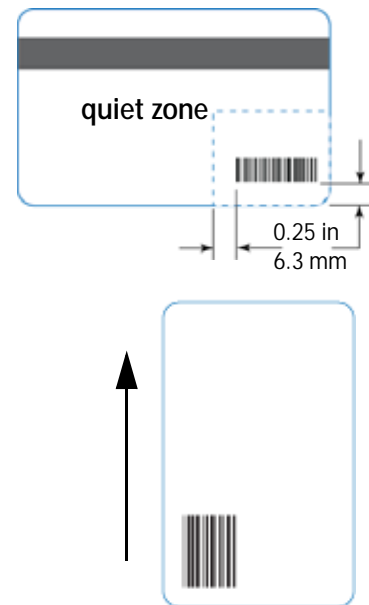

Bar Code Size

- A lower density bar code is easier to read, because the bars are wider and spaced farther apart.
- The width of the narrow elements in the bar code must be large enough to be read consistently. The capabilities of the bar code reader can influence this.
- The bar code must be tall enough to be read under normal conditions.

Bar Code Print Settings

- To achieve the best quality printing and improve the readability of the bar code, use the K (black) panel of color print ribbon to print the black bars. Bar codes printed with YMC panels are not as crisp and sharp as those printed with the K panel only. Refer to the printer's *Driver Guide* or the documentation for your card personalization software for more information about how to print bar codes using the K panel.
- Infrared readers require that the K panel be used to print the bar code.

Test Bar Codes

Always test the readability of bar codes under production conditions. Factors to consider include:

- If you print cards one at a time, print the samples using that method. If you print cards in batch (many cards sent to the printer at the same time), use a production-sized batch and evaluate cards from the beginning, middle, and end of the batch.
- Use exactly the same card stock for testing that you use for production. The card stock can affect the readability of bar codes. Usually, a white surface that reflects light in many directions is needed. Test cards before purchasing production quantities.
- Include other card design components that you use in production, such as topcoat.
- Use the same bar code readers as users have, and test each card multiple times to simulate any wear the card might experience. Also test multiple cards.

Card Design Changes That Affect Bar Codes

If you make substantial changes to the way you produce cards, review your setup tasks to make sure that cards continue to have the quality you require.

Changes that can affect bar codes include:

- Purchasing a new brand of card stock, which can change the color of some images.
- Changing to, or from, preprinted cards, which can change the color of some images.

If you change the design of your cards, or if you start producing an additional card design, test each design as described in “[Test Bar Codes](#)” on [page 35](#) to make sure that the bar code prints as expected.

Print Bar Codes With the Card Printer Driver

The Card Printer Driver includes a setting that allows the printer to use the black (K) panel to print the bars of a bar code embedded in a color image, making it more likely to be read by a scanner. Refer to the printer’s *Driver Guide* for complete information about how to specify the “Print black image pixels using monochrome” option.

Apply Topcoat

Full-color and UV printing fades if it lacks topcoat protection. Topcoat protects the printed image on the card. It is applied as an even, consistent film.

Make sure that all color printing is covered with topcoat (except for areas such as a magnetic stripe, smart card chip, or signature panel).

When a ribbon with a topcoat (T) panel is installed, the printer can apply topcoat to the card using the printhead. Most full-color ribbons include topcoat panels.

Topcoat must be requested by the application sending the card to the printer. Most card production software requests topcoat automatically.



Do not apply topcoat over the magnetic stripe, smart card chip, or signature panel of a card. To prevent topcoat application, you must specify a non-printing area.

If your system is equipped with a laminator, you can use it to apply overlay material to the front and back of the card for durability and security. Refer to [“Laminator Supplies”](#) on [page 102](#) for information about the types of overlays available.

Non-Printing Areas

The card design can have areas where printing is not allowed. Such areas include a magnetic stripe, signature panel, or smart card chip. Card production software and the Card Printer Driver usually manage such non-printing areas automatically. If you do not use ID software, you can use the dimensions provided in the following sections for magnetic stripe and smart card non-printing areas to customize your print and topcoat areas.



- Blocking for non-printing areas typically extends 0.05 inch (1.27 mm) beyond the edges of a feature. The dimensions listed in the following sections include the extended blocking region.
- Print several cards using your card design and application to verify that printing and topcoat are applied as you intend.

The dimensions shown in the following sections are examples to help you determine the non-printing area. The actual dimensions can vary depending on the card stock you use.

Standard Magnetic Stripe Non-Printing Area

The magnetic stripe typically is on the back of the card.

The following table shows the standard measurements for magnetic stripes. Use these values if you need to define a non-printing area. The non-print blocking area must extend outside the magnetic stripe by 0.05 in (1.27 mm), indicated by the dotted lines.

	A	B	C
3-track	5.0 mm	13.5 mm	86 mm
2-track	6 mm	9 mm	86 mm
Single-track (JIS)	7.5 mm	7.5 mm	86 mm

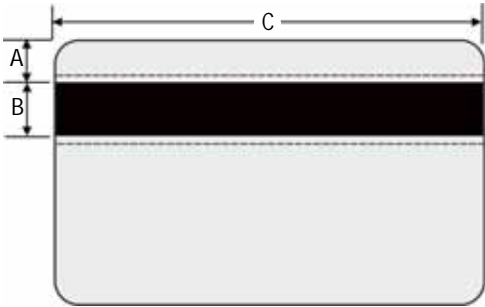

Standard Smart Card Non-Printing Area

The smart card area typically is on the front of the card.

The following table shows the measurements for a typical smart card chip. The smart card chip can vary in size, shape, and location. Adjust these values based on the card stock you use. The non-print blocking area must extend outside the smart card chip by 0.05 in (1.27 mm), indicated by the dotted line.

A	B	C	D
19.5 mm	10 mm	13 mm	12 mm

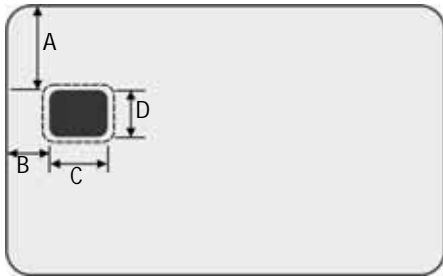

Custom Non-Printing Areas

Use ID software, a custom application, or escapes to define custom non-printing areas for one or more of the following:

- Blocking printing but not topcoat
- Non-standard areas, such as a preprinted logo or a signature panel
- More than one area on the same side of the card, such as a magnetic stripe and a signature panel

Card Layout

The arrangement or layout of components determines how well your card design works for users. Follow these guidelines to position card design components for best results.

Margins

Any unprinted area at the edge of the card or around the perimeter of a card feature is called the margin.

Margins at the Edge of a Card

The card printers print edge-to-edge, which means the printing is as close to the edge of the card as possible. When you set up your card design, you specify a margin of 0, or no margin. The printer leaves a small white margin around the edges of the card due to the printhead being lowered and raised as it prints. Keep this in mind if your card design includes a full-card image.

You can attempt to move the printing closer to the edge of the card by adjusting the LeadTrim and TrailTrim settings in Printer Manager, but be aware that this can cause the print ribbon to break when cards are printed. Refer to [“Print” on page 65](#). Include this task as part of setup.

The following illustration shows the margin of white space at the outer edge of the card.

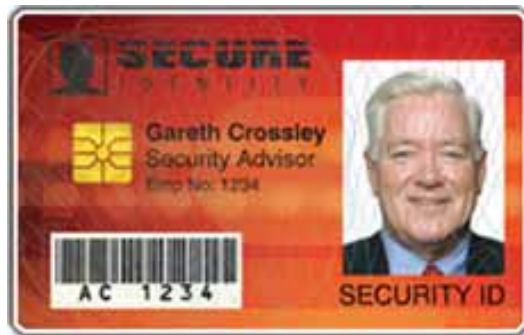

Margins for Card Features

Maintain a margin between printing and card features, such as a signature panel, magnetic stripe, or smart card chip. For best results, do not print closer than 0.05 inch (1.27 mm) from those features.

Backgrounds

Use the following suggestions to help you select a background for a professional-looking card. For best results, make sure that the background design does not emphasize the location of card features, such as embedded electronics.

- Consider using a white background for the card to achieve consistent professional results.
- Consider using smaller blocks of color, patterned areas, or gradients to highlight printed card features such as a name, photo, or logo.
- Avoid using a solid-color background over a large area of the card. It can show flaws on the card (such as an uneven surface) or the location of card features (such as a smart card chip).

Image Placement

Use the following suggestions to help you locate important images, such as a photo, logo, or bar code. When placing images, avoid uneven areas and areas of high wear, which can result in inconsistent print quality.

- Do not place an important image on the front of the card in the same area as a magnetic stripe or other machine-readable feature. Frequent use of a card in a reader can wear away the image on the opposite side of the card.
- Do not place an important image directly on the opposite side of a signature panel. This can cause residue from the signature panel to interfere with printing on an adjacent card. Place the image above, below, or to the side of the panel.
- Do not place an important image directly on the opposite side of a smart card chip. The card might not be as flat in that area, and printing voids may occur.

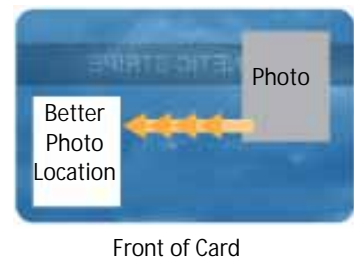

Magnetic Stripe Design

The printer's magnetic stripe module allows the printer to process magnetic stripe data. There are two magnetic stripe configuration options: ISO and JIS. Use the Printer Configuration Label (described in the printer's *User's Guide*) to determine the type of module installed.

Magnetic Stripe Data Formats

The module format (ISO or JIS) defines the type and format of the information to encode. The standard ISO format (also known as IAT) is a three-track option. The JIS format is a single-track option. Both formats include default data settings that determine how many characters can be encoded on each track, and which characters can be encoded.

Your cards can use the default format for each track, or can use a different combination of tracks and data formats.

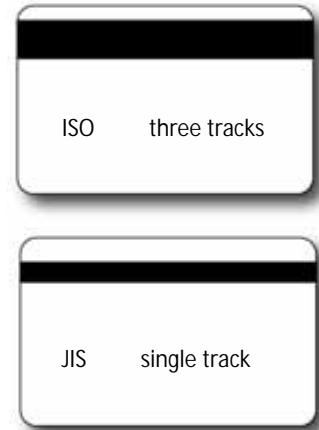

Three-Track Option (ISO/IAT)

The default data formats for a three-track magnetic stripe option are:

- Track 1 — IATA
- Track 2 — ABA
- Track 3 — TTS

This combination is often abbreviated IAT. This format is also called ISO format.

IATA (International Air Transport Association)

The maximum number of characters for IATA format data is 76 characters. These characters can include spaces, uppercase alphabetic characters (A–Z), numeric characters (0–9), and the following special characters:

! # \$ % ' () * + , - . / ; : < @ > = ^] \ [" & _

ABA (American Bankers Association)

The maximum number of characters for ABA format is 37 characters. Numeric characters (0–9) and the following special characters are allowed:

: ; < = >

TTS (Thrift Third Standard)

The maximum number of characters for TTS format is 104 characters. Numeric characters (0–9) and the following special characters are allowed:

: ; < = >

Single-Track Option (JIS)

The default data format for a single-track magnetic stripe module is the JIS (Japanese Industrial Standard) Type II format.

The maximum number of characters for the JIS format is 69 characters. These characters can include spaces, numeric characters (0–9), uppercase alphabetic characters (A–Z), lowercase alphabetic characters (a–z), and the following special characters:

! " # \$ % & ' () * + , - . / : ; < = > ? @ [] ^ _ ~ { | } ~

A PC running a Japanese edition of a supported Windows operating system also supports Japanese-language special characters and 55 Katakana characters. They include the following:

- Special characters:

。 『 』 、 ・ ー * °

- 45 Katakana characters:

アイウエオ
カキクケコ
サシスセソ
タチツテト
ナニヌネノ
ハヒフヘホ
マミムメモ
ヤ ュ ヨ
ラリルレロ
ワ ン

- 10 Katakana characters:

ヲ アイウエオヤユヨツ



The magnetic stripe data uses shift-JIS, which embeds a hidden "shift-in" and "shift-out" character each time the Japanese-language characters start and end. Each transition between normal characters and shifted characters is surrounded by these two control characters. They are encoded on the magnetic stripe. Thus, each hidden character reduces the number of characters you can encode by one character.

Magnetic Stripe Coercivity

The printer may require additional settings to match the coercivity of the card. When these values are set they remain the same for all cards processed using the same design. The defaults are set to standard ISO format and high coercivity. Refer to [“MagStripeGeneral”](#) on [page 72](#) for information about changing the coercivity.

The type of magnetic stripe cards you use must match the type of module (ISO or JIS) installed. Test your printer to make sure that it is encoding magnetic stripe information properly.

Smart Card Design

Smart card processing differs from other types of card personalization. The “smart card” step of personalization is controlled by an application that is separate from the rest of card personalization.

The smart card reader can be factory-installed, or installed later as a field upgrade by a service provider or value-added reseller. The printer configuration label (or a label attached at the time of the field upgrade) shows the type of smart card reader installed. You can request additional information about the smart card reader and the type of cards to use from your service provider or value-added reseller.

Smart Card Processing Requirements

The following items are required to personalize smart cards:

- A smart card reader in the printer
- A cable for the smart card port used (this cable is not needed for single-wire processing)
- A card production application that is designed to work with the printer and the smart card application
- Smart cards that work with the reader in the printer

Smart Card Codes on the Printer Label

The configuration label includes codes that identify the type and model of the smart card module installed in the printer. The following table lists the codes used on the configuration label.

Code on Label	Type of Smart Card Module
S1	Integrator Contactless
S3	HID pcProx Contactless
S4	iCLASS Read Contactless
S5	iCLASS Read/Write Contactless
S6	DUALi Standard
S7	DUALi Single Wire
S8	DUALi Single Wire Sony Felica
S9	GEMPC USB / pcProx Dual
S10	Contact Station
S11	Identive Dual Interface Reader
S12	pcProx Plus Dual Frequency
S13	DUALi Single Wire Large Memory

The S1 value on the configuration label indicates that the printer has the basic smart card components installed. Basic components include the mounting hardware only. An integrator must install a contactless reader.

If the Sx value is included in the configuration code, the printer has the basic components of an S1, plus the appropriate interface installed.



The smart card readers available may vary by printer model. Contact your authorized dealer for more information.

Single-Wire Smart Card

Single-wire smart card processing allows a single USB or Ethernet connection with the printer to carry data for both smart card personalization and printing.

The single-wire smart card feature is available to an application through the Windows Driver Software Development Kit (SDK), or through your card personalization software.



The single-wire smart card programming interface is similar, but not identical, to the PC/SC standard. Applications using PC/SC to personalize smart cards require modification to use the single-wire smart card interface.

Required components for single-wire smart card are the same as for other smart card systems except as noted.

Settings for Card Design in Printer Manager

Printer Manager contains card design settings that managers and service providers can use to set up card production. The card design settings include magnetic stripe setup and smart card testing. Printer Manager also contains troubleshooting features such as a log file that can track all processes of a card job. Service providers can use the information in the log file to troubleshoot and relay information when troubleshooting card processing issues. Refer to [Chapter 3: "Printer Manager"](#) for more information.



Chapter 3: Printer Manager

3

This section describes Printer Manager, the Datacard web interface available to users, administrators, and service providers.

Printer Manager

Printer Manager is a browser-based interface that displays information about the printer. System administrators and service providers can use Printer Manager to fine-tune card appearance, set advanced options, and troubleshoot printing problems. You can access Printer Manager using an Internet browser and the IP address of the printer.

Printer Manager includes different user access levels that control the type of information that can be viewed. You can choose from three user access levels to perform a variety of basic and advanced tasks: WebUser, WebAdmin, and WebService.

Printer Manager User Access Levels

The **Username** field controls the level of access to information and settings that correspond to the user's job responsibility.

WebUser

WebUser access allows users to view information and change a limited amount of values. The WebUser access level typically is used by the person responsible for printing cards. Other responsibilities can include cleaning the printer, ordering printer supplies, or printing a daily or weekly log of card production.

The WebUser access level displays four menu selections: Status, Printer Setting, Maintenance, and Log Out.

WebAdmin

WebAdmin access allows an administrator to set up a test card and make minor adjustments to the printer. The WebAdmin user has access to configuration options and the use of diagnostics tools for troubleshooting. The WebAdmin user also can specify a password (using the **Printer Settings > Update Password** option) for WebUser access-level users.

In a card production environment, the WebAdmin access-level user typically sets up the card design, verifies communication with external data sources, and tracks printer activity and performance.

WebService

WebService access has all of the above adjustments with additional access to adjust offsets.

The WebService user typically is an Entrust Datacard-trained service provider.

Access Printer Manager

The initial Printer Manager screen allows users to log on with a user name and password that determine their user access level. The user access level determines which menu items, options, and adjustments are available.

1. Make sure that the printer's LCD panel displays **Ready**.
2. Access Printer Manager in one of the following ways:
 - a. If you use the Card Printer Driver, open the **Printer Properties** window for the printer and select the **Printer Status** tab.
 - b. Click **Configure Printer** to launch Printer Manager in your default browser.

OR

- a. Obtain the printer network IP address and write it down. Refer to the printer's *User's Guide* for detailed information about how to retrieve the printer IP address.
- b. Open a web browser on the PC and enter the IP address:

IPv4: Enter the address using the following format: `https://xxx.xxx.xxx.xxx`

For example: `https://123.12.3.123`

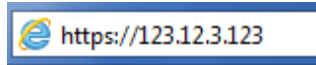

IPv6: Enter the address using the following format. You must enclose the IPv6 address in brackets ([and]).

`https://[xxxx:xxxx:xxxx:xxxx:xxxx:xxxx:xxxx:xxxx]/`

An IPv6 address is represented as eight groups of four hexadecimal digits separated by colons. For example, `2001:0db8:0000:0000:0000:ff00:0042:8329`

However, you can abbreviate the address as follows:

- ◆ Remove one or more leading zeros from a group—`2001:db8:0:0:0:ff00:42:8329`
- ◆ Replace consecutive sections of zeros with a double colon (::). You can do this only once in the address—`2001:db8::ff00:42:8329`

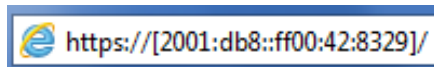

When you use a secure protocol (https), the browser may display a warning message indicating a problem with the website's security certificate. Continue to the website to access Printer Manager.

3. The Printer Manager Log In screen displays.

4. Select the language in which to display the Printer Manager session from the Select Language column.
5. In the Please Log In section, select a Username that matches your job responsibility and enter a password (if required). Refer to “Printer Manager User Access Levels” on page 48 for a description of the user access levels.
6. Click **Log In** to display the Printer Manager Welcome page.

HINTS & TIPS

- If the browser cannot connect to the printer, make sure that **Ready** displays on the LCD panel of the printer.
- Some Printer Manager pages feature hover text that displays help information when the cursor hovers over the setting in the description column.

Printer Manager Settings

The printer is shipped with recommended settings in Printer Manager. You may need to change these settings to customize the printer for your site. Printer Manager provides access to the printer settings.

Many of the Printer Manager menu options display the **Set Current** and **Restore Default** buttons.

- **Set Current** saves any changed settings on the displayed page. When you change a value and click **Set Current**, the printer uses the new settings until the default values are restored. If you exit a page without clicking Set Current, your changes are not applied.



If you enter a value outside the allowed range for a setting, the settings are not updated and a message displays asking you to correct your entry.

- **Restore Default** restores the default settings to the values on the displayed page.

Print a Printer Manager Page

Use your Internet browser Print option to print the information from any Printer Manager page to a paper printer.

- Select **File > Print** from your Internet browser's main menu.
- If the printed page does not display all the information from the Printer Manager, select **File > Print Preview** in your Internet browser to scale the image to fit the paper.

Use Printer Manager

The following sections describe how to use the options on the Printer Manager menus that are available to WebUser and WebAdmin access-level users. For information about settings available to the WebService access level, contact your service provider.



The options available in Printer Manager are determined by the printer model and the options installed on the printer. The Printer Manager options described in the following sections may not be available for all printers.

Status Menu

The **Status** menu displays general information about the printer and its usage statistics. Users at all access levels can view or print the Status menu information. You cannot change the information on the Status menu.

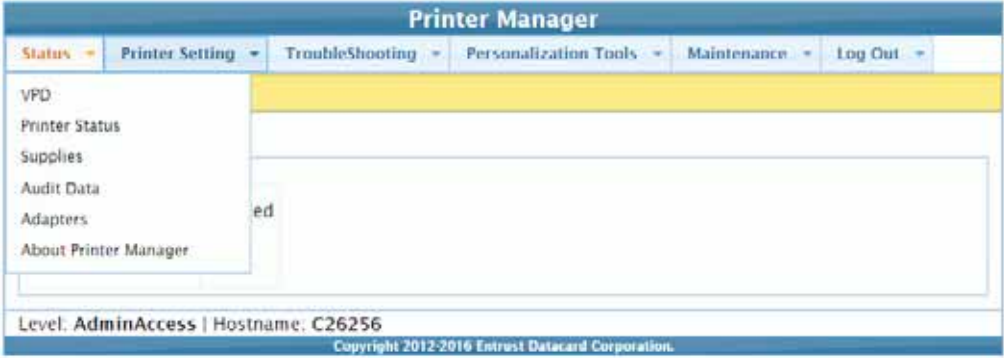

Status Menu Option	Function	WebUser	WebAdmin
VPD	Display printer vital product data (VPD), including the manufacturer, model, installed options, serial numbers, and version numbers. Print this page for reference if you need to contact your service provider.	View	View
Printer Status	Display printer status information, including the printer mode, the printer state, how long the printer has been powered on (in seconds), current conditions, and job status.	View	View
Supplies	Display information about the supplies currently installed in the printer. This includes the part number and serial number, additional codes that define the supply, and the percent of supply remaining in relation to a new full roll. For printers with more than one supply module, information displays for each module type.	View	View

Status Menu Option	Function	WebUser	WebAdmin
Audit Data	Display card printer usage data, including card counts (both resettable—shown with an r as the first letter of the name—and non-resettable counts) and error reporting collected by the printer. This page acts as a general overview for all the counters and can be useful to track card production activity and problem history.	View	View
Adapters	Display information about the IP addresses configured for the printer. The printer can have an IPv4 address and multiple IPv6 addresses configured concurrently. The page shows the IP address, network mask (or IPv6 prefix), gateway address, and MAC address for each adapter.	View	View
About Printer Manager	Display the Printer Manager software version and copyright information.	View	View

Printer Setting Menu

Use the **Printer Setting** menu to view and customize printer settings.

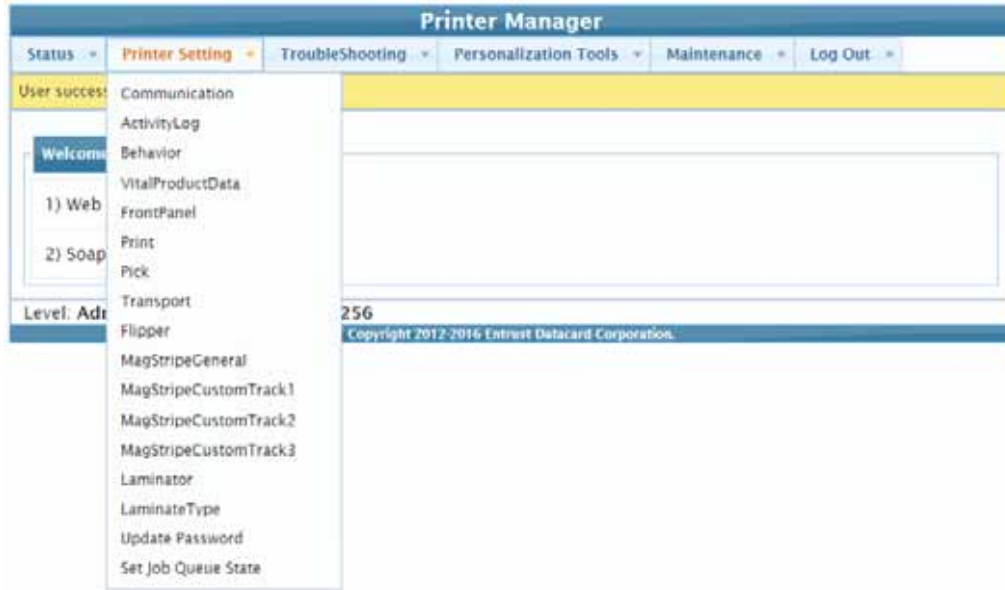

Printer Setting Menu Option	Function	WebUser	WebAdmin
Communication	Set or view the network address method used by the printer.	No	Change Current Values
ActivityLog	Set values in the activity log to help isolate card production issues.	No	Change all Current Values
Behavior	Display printer operation and control methods.	Change RibbonInitialize	Change all Current Values
VitalProductData	Change printer information. Available to Webservice access level users only.	No	No
FrontPanel	Set front panel values for the printer.	Change Backlight Brightness, KeySenseLevel and SpeakerEnabled values	Change all Current Values

Printer Setting Menu Option	Function	WebUser	WebAdmin
Print	Set print parameters for color management, print intensity, and registration settings.	No	Change all Current Values
Pick	Display and set pick values. Available to WebService access level users only.	No	No
Transport	Set the eject speed of the hopper and the transport motor speed.	View only TransMedSpeed	View only: TransMedSpeed; Change: EjectHopper Speed
Flipper	Set values for the duplex module in duplex-option printers. Available to WebService access level users only.	No	No
MagStripeGeneral	Set magnetic stripe options including coercivity, custom magnetic stripe formats, and data formats.	No	Change coercivity, custom formats, and data formats
MagStripeCustomTrack1	Set customized magnetic stripe values for track 1.	No	Change all Current Values
MagStripeCustomTrack2	Set customized magnetic stripe values for track 2.	No	Change all Current Values
MagStripeCustomTrack3	Set customized magnetic stripe values for track 3.	No	Change all Current Values
Laminator	Specify laminator settings	Change all Current Values	Change all Current Values
LaminateType	Specify overlay settings	Change all Current Values	Change all Current Values

Printer Setting Menu Option	Function	WebUser	WebAdmin
Update Password	Set or update passwords for the WebUser and WebAdmin access levels.	No	Change WebUser and WebAdmin passwords
Set Job Queue State	Enter values for shipping the printer to a repair facility, or when securing the printer to perform troubleshooting, maintenance, or other procedures. This setting is used primarily by financial printers. Contact your service provider for more information.	Requires a password	Requires a password

Communication

Use the **Communication** settings to specify the network address method used by the printer.

Description	Default Value	Current Value (unit)	Allowed Range
1) EthAddressMethod	DHCP	DHCP	
2) EthDnsAddress1	0.0.0.0	0.0.0.0	
3) EthDnsAddress2	0.0.0.0	0.0.0.0	
4) EthDnsSearchSuffix			
5) EthGatewayAddress	0.0.0.0	0.0.0.0	
6) EthIpAddress	0.0.0.0	0.0.0.0	
7) EthSubnetMask	0.0.0.0	0.0.0.0	
8) IPMode	IPv4	DualStack	
9) IPv6DefaultGateway	::	::	
10) IPv6DHCPv6Select	Enabled	Enabled	
11) IPv6DNSPrimaryAddress	::	::	

Description	Default Value	Current Value (unit)	Allowed Range
12) IPv6DNSSecondaryAddress	::	::	
13) IPv6ManualAddress	::	::	
14) IPv6ManualPrefixLength	64	64	[0 – 128]
15) IPv6ManualSelect	Disabled	Enabled	
16) IPv6StatelessAddrSelect	Enabled	Disabled	

- **EthAddressMethod**—The method used to obtain the IPv4 network IP address. Select **DHCP** or **STATIC** from the Current Value drop-down list.
 - When the value is DHCP, the **EthGatewayAddress**, **EthIpAddress**, and **EthSubnetMask** values are controlled by the DNS server and the settings are filled in automatically.
 - When the value is STATIC, the **EthGatewayAddress**, **EthIpAddress**, and **EthSubnetMask** values must be set manually.
 - ◆ **EthGatewayAddress**—Enter the gateway address for the Ethernet network.
 - ◆ **EthIpAddress**—Enter the static IP address for the printer.
 - ◆ **EthSubnetMask**—Enter the subnet mask for the Ethernet network.
- **EthDnsAddress1**, **EthDnsAddress2**, **EthDnsSearchSuffix**—These settings are not used at this time.
- **IPMode**—Specify the IP mode used by the printer. The printer can support both IPv4 and IPv6 addressing. You can select from the following
 - **IPv4**—The printer uses IPv4 addressing only.
 - **DualStack**—The printer can use both IPv4 and IPv6 addressing.

The remaining IPv6 settings become applicable when **IPMode** is set to **DualStack**.
- **IPv6DefaultGateway**—Set a default gateway address. This setting is disabled when set to the default of "::".
- **IPv6DHCPv6Select**—Select whether or not the printer obtains an address and stateful configuration from a DHCPv6 server. Disable this setting if a DHCPv6 server is not present.
- **IPv6DNSPrimaryAddress**, **IPv6DNSSecondaryAddress**—These settings are not used at this time.

- **IPv6ManualAddress**—Enter the IPv6 address using the following format:
XXXX:XXXX:XXXX:XXXX:XXXX:XXXX:XXXX:XXXX

Refer to “[Access Printer Manager](#)” on [page 48](#) for more information about entering an IPv6 address.

IPv6ManualSelect must be set to **Enabled** for the printer to use this setting.

- **IPv6ManualPrefixLength**—Specify the IPv6 manual subnet prefix length. IPv6 addresses consist of two parts. The prefix length indicates the boundary between the subnet to which the host is connected and the device ID in the IPv6 manual address, starting from the left end. The default value is 64.
- **IPv6ManualSelect**—Enable the printer to use the manual address specified in **IPv6ManualAddress**. If this setting is disabled, the manual address information specified for the printer is retained, but is not used.
- **IPv6StatelessAddrSelect**—Enable the printer to allow the router to provide one or more network prefixes used for stateless automatic address configuration (SLAAC).

To modify the Communications settings:

1. Enter your changes in the **Current Value** fields.
2. Click **Set Current** to apply the changes.
3. Log out of Printer Manager, and then restart it for the changes to take effect.

ActivityLog

The **ActivityLog** settings allow you to record technical information about the printer. WebAdmin or WebService access-level users can change settings in the activity log to help troubleshoot and isolate a card production problem. You specify the types of actions to include in the logs and set the severity level for when the action should be written to the log. Filter severity level options include: Critical, Error, Warning, Notice, Information, Debug, Disabled.

Description	Default Value	Current Value (unit)
1) ExternalLog	Disabled	Disabled
2) ExternalLogServer	0.0.0.0	0.0.0.0
3) FilterCardActions	Notice	Notice
4) FilterConfigChanges	Notice	Notice
5) FilterJobStates	Notice	Notice
6) FilterSoapMsgs	Notice	Notice
7) FilterSystem	Notice	Notice
8) InternalLog	Enabled	Enabled

- **ExternalLog**—Enable or disable writing the activity log to an external Syslog server.
- **ExternalLogServer**—Specify the IP address of the external Syslog server if you are writing to an external log (ExternalLog is set to Enabled).
- **FilterCardActions**—Write the start and completion of a card action with the specified severity, and higher, to the activity log.
- **FilterConfigChanges**—Write configuration change actions with the specified severity, and higher, to the activity log.
- **FilterJobStates**—Write changes to the state of a print or exception job with the specified severity, and higher, to the activity log.
- **FilterSoapMsgs**—Write DPCL/Soap (Simple Object Access Protocol) messages from the printer with the specified severity, and higher, to the activity log.
- **FilterSystem**—Write system information with the specified severity, and higher, to the activity log. A value of Information results in most events being written to the log.
- **InternalLog**—Enable or disable the activity log on the printer.

Activity Log Example:

Change the FilterJobStates status recorded in the activity log to help isolate a card production problem.

1. Select **Printer Setting > Activity Log**.
2. Set **FilterJobStates** to **Error** from the drop-down list. Changes to the state of a job, with this severity and higher, are written to the activity log.
3. Click **Set Current** to apply the changes.

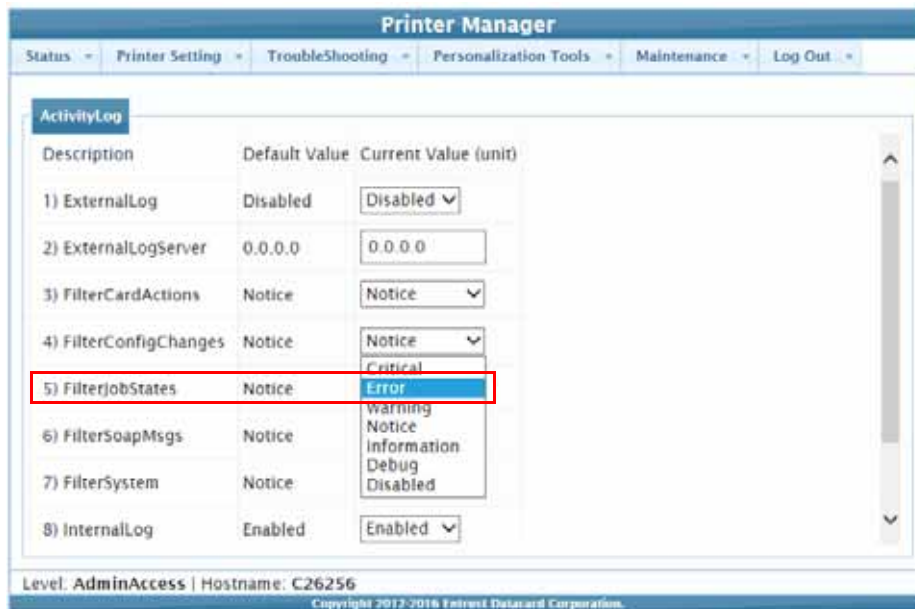

Description	Default Value	Current Value (unit)
1) ExternalLog	Disabled	Disabled
2) ExternalLogServer	0.0.0.0	0.0.0.0
3) FilterCardActions	Notice	Notice
4) FilterConfigChanges	Notice	Notice
5) FilterJobStates	Notice	Error
6) FilterSoapMsgs	Notice	Warning
7) FilterSystem	Notice	Notice
8) InternalLog	Enabled	Information

Level: AdminAccess | Hostname: C26256
Copyright 2012-2016 Entresol Datacard Corporation.



We recommend that you operate at all default logging settings to reduce unnecessary logging for typical printer operations.

Behavior

Use the Printer Setting menu **Behavior** settings to control printer operation.

Description	Default Value	Current Value (unit)	Allowed Range
1) ActivityLogExternal	Enabled	Enabled	
2) ActivityLogInternal	Enabled	Enabled	
3) ContactAutoDetect	Disabled	Disabled	
4) ContactlessATRMMode	Legacy	Legacy	
5) CPX	Enabled	Enabled	
6) DataStorageSecure	Disabled	Disabled	
7) DPCL	Enabled	Enabled	
8) DPCL2	Enabled	Enabled	
9) DPCL2Secure	Enabled	Enabled	
10) DPCLSecure	Enabled	Enabled	
11) NetworkAccessControl	Disabled	Disabled	
12) Plugin	Enabled	Enabled	
13) Remake	Enabled	Enabled	
14) RemakeMethod	Conserve Supplies	Conserve Supplies	
15) RetrieveDataTimeout	120	120	[0 – 120]
16) RibbonInitialize	Enabled	Enabled	
17) SNMP	Enabled	Enabled	
18) WebServerSecure	Enabled	Enabled	

Update Current Values as needed, and then click **Set Current** to apply changes.

- **ActivityLogExternal**—Enable or disable writing the activity log to an external server.
- **ActivityLogInternal**—Enable or disable the internal activity log.
- **ContactAutoDetect**—This setting supports legacy smart card clients. It overrides the smart card protocol sent by the client to the printer and uses SCARD_PROTOCOL_T0_OR_T1. The setting is set to **Disabled** by default.
- **ContactlessATRMode**—Select the default ATR mode for the DUALi contactless smart card reader. The possible values are:
 - **Vendor**—Uses the ATR mode specified by the vendor. The generated ATR may not be compatible with all smart card applications or card types.
 - **PCSC**—Uses the PC/SC protocol to generate the ATR.
 - **CCID**—Uses the CCID protocol to generate the ATR.
 - **Legacy**—Uses the ATR mode currently in use by the reader. This is the default value.
 - **AppSpecifies**—Allows the smart card application to control the ATR mode.



A smart card application may specify to receive the ATR in a different format regardless of this setting. However, when the printer restarts, the smart card reader returns to the setting specified here. Consider whether you want to specify the format on a job-by-job basis or modify the Printer Manager setting to use the desired ATR format.

- **CPX**—Enable or disable the CPX communications protocol used by some Datacard systems.
- **DataStorageSecure**—Allows you to encrypt the data stored on the printer's internal SD card. Encrypting data provides extra security in the event the printer is stolen or disassembled and the SD card removed. Once data is encrypted, there is no impact on performance of the printer.
 - **Enabled**—Encrypts the printer data. Restart the printer after you select Enabled. The printer encrypts the data during the startup process. Encrypting the internally stored data takes approximately 20 minutes. the printer cannot be used until the encryption operation completes.
 - **Disabled**—Disables encryption of the internal printer data. When you select Disabled and restart the printer, the data is decrypted during printer shutdown. The decryption process takes approximately 20 minutes. The printer restarts when the decryption is complete. Disabled is the default setting for DataStorageSecure.
- **DPCL**—Enable or disable DPCL command access to the printer through the non-secure port. DPCL must remain enabled when you use the XPS Card Printer Driver.
- **DPCL2**—Enable or disable DPCL2 command access to the printer through the non-secure port.

- **DPCL2Secure**—Enable or disable DPCL2 command access to the printer through the secure port.
- **DPCLSecure**—Enable or disable DPCL command access to the printer through the secure port.
- **NetworkAccessControl**—Enable or disable network access control.
- **Plugin**—Enable or disable the plugin feature for the printer to access an installed plug-in. This setting is used for OpenCard-enabled printers.
- **Remake**—Enable or disable card remakes. If Remake is set to Enabled and a print request fails, the print request is tried again with a new card. A card is retried only once.
- **RemakeMethod**—Select the card remake method. This setting does not display if Remake is set to Disabled.
 - Select **ConserveSupplies** to reprint the card out of queue order.
 - Select **PreserveOrder** to reprint the card in queue order.
- **RetrieveDataTimeout**—Specify the time period during which card data can be retrieved. You can specify from 0 to 120 seconds. If the Current Value is 0, data is not retrieved.
- **RibbonInitialize**—Enable or disable initialization of the ribbon when the printer is powered on.
- **SNMP**—Enable or disable SNMP Service.
- **WebServerSecure**—Enable or disable access to Printer Manager (the web server) through the secure port.



Caution: Do not disable the web server. If the web server is disabled, you cannot launch Printer Manager and configuration changes cannot be made. To reverse this action, you must contact Entrust Datacard. To restrict access for the WebAdmin access level, select **Printer Setting > Update Password** and specify a password.

VitalProductData

The **VitalProductData** settings allow **WebService** access level users to change information about the printer or system in specific circumstances. Contact your service provider should it become necessary to modify the **VitalProductData** settings.

FrontPanel

Use the **FrontPanel** settings to customize the printer front panel.

Description	Default Value	Current Value (unit)	Allowed Range
1) BacklightBrightness	100	100	[0 – 100]
2) KeySenseLevel	5	5	[0 – 10]
3) LcdConfigMenu	Enabled	Enabled	
4) LedCardsPickedToCleaning	500	500	[0 – 1000000]
5) LedPrintheadCyclesToCleaning	2500	2500	[0 – 1000000]
6) LedRibbonLow	10	10	[0 – 1000000]
7) SpeakerEnabled	Enabled	Enabled	

Change the front panel settings as needed, and then click **Set Current** to apply the changes.

- **BacklightBrightness**—Set the LCD front panel backlight brightness at the desired level, from 0 percent (no backlight) to 100 percent (bright).
- **KeySenseLevel**—Set the front panel key sensitivity to a comfortable level. Select from 0 (low sensitivity, almost a press) to 10 (high sensitivity, barely a touch).
- **LcdConfigMenu**—Enable or disable access to the Configuration menu on the LCD panel menu system. (The Status and Maintenance menus cannot be disabled.)
- **LedCardsPickedToCleaning**—Set the number of cards to pick between required cleaning. The card light blinks amber when the printer reaches this value. If this value is set to 0, cards between cleaning are not tracked. We recommend that you clean the printer after every 500 cards to maintain print quality.
- **LedPrintheadCyclesToCleaning**—Set the number of printhead cycles between required cleaning. The card light blinks amber when the printer reaches this value. If this value is set to 0, cycles between cleaning are not tracked.
- **LedRibbonLow**—Set the percentage of ribbon remaining before being notified that the ribbon is low and should be changed. The ribbon light blinks amber when the ribbon reaches this value.
- **SpeakerEnabled**—Enable or disable the external printer speaker. The speaker provides a sound in addition to the front panel lights and LCD text.

Print

The **Print** selections provide a WebAdmin access-level user with the ability to fine-tune print quality.

Description	Default Value	Current Value (unit)	Allowed Range
1) CardRegistration	0	0	[-0.5 – 50.8]
2) ColorManagement	sRGBColorSpace	None	
3) ColorMatchB[0]	0	0	[0 – 255]
4) ColorMatchB[1]	0	25	[0 – 255]
5) ColorMatchB[2]	0	50	[0 – 255]
6) ColorMatchB[3]	0	75	[0 – 255]
7) ColorMatchB[4]	0	100	[0 – 255]
8) ColorMatchB[5]	0	125	[0 – 255]
9) ColorMatchB[6]	0	147	[0 – 255]
10) ColorMatchB[7]	0	170	[0 – 255]
11) ColorMatchB[8]	0	195	[0 – 255]
12) ColorMatchB[9]	0	219	[0 – 255]
13) ColorMatchB[10]	0	255	[0 – 255]
14) ColorMatchG[0]	0	0	[0 – 255]
15) ColorMatchG[1]	0	23	[0 – 255]
16) ColorMatchG[2]	0	48	[0 – 255]
17) ColorMatchG[3]	0	73	[0 – 255]
18) ColorMatchG[4]	0	99	[0 – 255]
19) ColorMatchG[5]	0	125	[0 – 255]
20) ColorMatchG[6]	0	150	[0 – 255]
21) ColorMatchG[7]	0	179	[0 – 255]

Description	Default Value	Current Value (unit)	Allowed Range
22) ColorMatchG[8]	0	209	[0 – 255]
23) ColorMatchG[9]	0	238	[0 – 255]
24) ColorMatchG[10]	0	255	[0 – 255]
25) ColorMatchR[0]	0	0	[0 – 255]
26) ColorMatchR[1]	0	27	[0 – 255]
27) ColorMatchR[2]	0	52	[0 – 255]
28) ColorMatchR[3]	0	80	[0 – 255]
29) ColorMatchR[4]	0	107	[0 – 255]
30) ColorMatchR[5]	0	134	[0 – 255]
31) ColorMatchR[6]	0	163	[0 – 255]
32) ColorMatchR[7]	0	191	[0 – 255]
33) ColorMatchR[8]	0	217	[0 – 255]
34) ColorMatchR[9]	0	240	[0 – 255]
35) ColorMatchR[10]	0	255	[0 – 255]
36) FPower	0	0	[-100 – 100]
37) FPowerDuplex	0	0	[-100 – 100]
38) KCustom1Power	0	0	[-100 – 100]
39) KCustom1Power1200DPI	0	0	[-100 – 100]
40) KCustom1Power600DPI	0	0	[-100 – 100]
41) KPower	0	0	[-100 – 100]
42) KPower1200DPI	0	0	[-100 – 100]
43) KPower600DPI	0	0	[-100 – 100]
44) KPowerDuplex	0	0	[-100 – 100]

Description	Default Value	Current Value (unit)	Allowed Range
45) KWhiteShade	0	0	[-100 – 100]
46) LeadTrim	0.254	0.254	[0 – 5.08]
47) SettingsGroupPurpose	Print	Print	
48) TPower	0	0	[-100 – 100]
49) TPowerDuplex	0	0	[-100 – 100]
50) TrailTrim	1.47	1.47	[0 – 5.08]
51) TWhiteShade	0	0	[-100 – 100]
52) VerticalOffset	17	14	[-100 – 100]
53) YMCPower	0	0	[-100 – 100]
54) YMCPower600	0	0	[-100 – 100]
55) YMCPowerDuplex	0	0	[-100 – 100]
56) YMCPowerNosRGB	-48	-48	[-100 – 100]
57) YMCWhiteShade	0	0	[-100 – 100]

Change settings as needed, and then click **Set Current** to apply changes.

- **CardRegistration**—Set the starting location of the printed area. The values are in mm (1 mm = 0.0394 in). The setting specifies the distance to move the card before printing.
 - Increase the value to move printing closer to the card's leading edge.
 - Decrease the value to move printing away from the card's leading edge.
- **ColorManagement**—Specify whether to use color management in the printer.
 - **None** disables color management in the printer and allows color management to be handled by the application.
 - **sRGBColorSpace** renders images to look similar to those displayed on PC monitors using the standard Red, Green, and Blue color space.
 - **MatchSP** results in printing that closely matches legacy card printers.

- **ColorMatchB[0–10], ColorMatchG[0–10], ColorMatchR[0–10]**—The ColorMatch settings for Blue(B), Green(G), and Red (R), are used by the printer to make sure that the print color output is consistent for all ribbon types. Each value has been calibrated so that the colors that print on a card are the same for every ribbon type. We recommend that you do not change these settings except under the guidance of your service provider.



If any of the ColorMatch settings are changed, they cannot be restored by clicking Restore Defaults. To restore the color match settings to their original values, set **ColorMatchR[10]** to **0** and click **Set Current**. Power off the printer, and then power it on again. This restores all 33 of the ColorMatch settings to their original calibrated values.

- **FPower**—Modify the print intensity for the F panel of UV ribbon.
 - Increase the value to make UV printing more defined on the card.
 - Decrease the value to reduce the UV intensity or prevent frequent ribbon breaks when printing with a UV ribbon.
- **FPowerDuplex**—Modify the print intensity for the back side F panel of UV ribbon.
 - Increase the value to make UV printing more defined on the card.
 - Decrease the value to reduce the UV intensity or to prevent frequent ribbon breaks when printing with a UV panel.
- **KCustom1Power**—Modify the print intensity for the non-black monochrome panel of MT-KT (ST-KT or GT-KT) ribbon.
 - Increase the value to make single-color printing thicker and more defined on the card.
 - Decrease the value to reduce the monochrome intensity or to prevent frequent ribbon breaks when printing with the M panel.
- **KCustom1Power1200DPI**—Modify the print intensity at 1200 dpi for the non-black monochrome panel of MT-KT (ST-KT or GT-KT) ribbon.
 - Increase the value to make single-color printing thicker and more defined on the card.
 - Decrease the value to reduce the monochrome intensity or to prevent frequent ribbon breaks when printing with the M panel.
- **KCustom1Power600DPI**—Modify the print intensity at 600 dpi for the non-black monochrome panel of MT-KT (ST-KT or GT-KT) ribbon.
 - Increase the value to make single-color printing thicker and more defined on the card.
 - Decrease the value to reduce the monochrome intensity or to prevent frequent ribbon breaks when printing with the M panel.

- **KPower**—Modify the print intensity for K (single-color) panel or K (single-color) ribbon.
 - Increase the value to make single-color printing thicker and more defined on the card.
 - Decrease the value for crisp bar codes or to prevent frequent ribbon breaks when printing with the K panel.
- **KPower1200DPI**—Modify the print intensity at 1200 dpi for the K panel or K ribbon.
 - Increase the value to make single-color printing thicker and more defined on the card.
 - Decrease the value for crisp bar codes or to prevent frequent ribbon breaks when printing with the K panel.
- **KPower600DPI**—Modify the print intensity at 600 dpi for the K panel or K ribbon.
 - Increase the value to make single-color printing thicker and more defined on the card.
 - Decrease the value for crisp bar codes or to prevent frequent ribbon breaks when printing with the K panel.
- **KPowerDuplex**—Modify the print intensity for the back-side K panel and K ribbons.
 - Increase the value to make single-color printing thicker and more defined on the card.
 - Decrease the value for crisp bar codes or to prevent frequent ribbon breaks when printing with the K panel.
- **KWhiteShade**—Modify the amount of power applied to the printhead to reduce ribbon friction without transferring material. Decrease the value if material transfers to the card when it should not.
- **LeadTrim**—Modify the number of millimeters to remove from the leading edge of a full-size image to keep it within the print area (1 mm = 0.0394 in. or about 11.8 dot rows).
- **SettingsGroupPurpose**—State the purpose of a settings group. Group names are not changeable. Use this option to identify the reason for creating a settings group.
- **TPower**—Modify the intensity of the T (topcoat) ribbon panel.
 - Increase the value to make printed topcoat thicker or more uniform.
 - Decrease the value to prevent frequent ribbon breaks while printing the topcoat.
- **TPowerDuplex**—Modify the intensity of the back-side T (topcoat) ribbon panel.
 - Increase the value to make printed topcoat thicker or more uniform.
 - Decrease the value to prevent ribbon breaks while printing the topcoat.

- **TrailTrim**—Modify the number of millimeters to remove from the trailing edge of a full-size image to keep it within the print area (1 mm = 0.0394 in. or about 11.8 dot rows).
 - Increase the value to lengthen the printed area.
 - Decrease the value to shorten the printed area.
- **TWhiteShade**—Modify the amount of power applied to the printhead to reduce ribbon friction without transferring material. Decrease the value if material transfers to the card when it should not.
- **VerticalOffset**—Modify the image placement on the card. Use this setting to align printing with the long edges of the card. Specify the number of printhead dots to shift printing toward the top or left side of the card. You cannot change the number of dots between the long edges of the card.
- **YMCPower**—Modify the intensity of the YMC (color) ribbon panels.
 - Increase the value to make the color printing more intense.
 - Decrease the value to reduce the color intensity or to prevent frequent ribbon breaks when printing colors.
- **YMCPower600**—Modify the print intensity at 600 dpi for the YMC (color) ribbon panels.
 - Increase the value to make the color printing more intense.
 - Decrease the value to reduce the color intensity or to prevent frequent ribbon breaks when printing colors.
- **YMCPowerDuplex**—Modify the intensity of the back-side YMC (color) ribbon panels.
 - Increase the value to make the color printing more intense.
 - Decrease the value to reduce the color intensity or to prevent frequent ribbon breaks when printing colors.
- **YMCPowerNosRGB**—Modify the intensity when you are printing without the sRGB color mode.
 - Increase the value to make the non-sRGB color darker
 - Decrease the value if using non-sRGB color mode to prevent overly dark printing or ribbon wrinkles or tears.
- **YMCWhiteShade**—Modify the amount of power applied to the printhead to reduce ribbon friction without transferring material. Decrease the value if unprinted or white areas of the card have color applied to them and should not.

Pick

The **Pick** settings define how cards are picked from the input hopper. **Pick** settings are available for WebService access-level users only. Contact your service provider for information about changing the printer's pick settings.

Transport

The **Transport** options allow you to set values for card travel through the printer.

Description	Default Value	Current Value (unit)	Allowed Range
1) EjectHopperSpeed	ehs_Standard	ehs_Standard	
2) TransMedSpeed	800	800	[300 – 1800]

Change settings as needed, and then click **Set Current** to apply changes.

- **EjectHopperSpeed**—Optimize the card eject speed based on the hopper type.
 - Select **ehs_Standard** if the printer has a standard output hopper.
 - Select **ehs_Extended** if the printer has an extended (100-card) output hopper.
-  If you have installed the 100-card output hopper, change the **EjectHopperSpeed** setting to **ehs_Extended** to allow completed cards to stack properly in the hopper.
- **TransMedSpeed**—The speed at which the transport motor runs when clearing errors. You cannot change this value.

Flipper

The **Flipper** settings define values for the duplex module in duplex-option printers. Flipper settings are available for WebService access-level users only. Contact your service provider for assistance if you need to change the printer's flipper settings.

MagStripeGeneral

Magnetic stripe settings are available for WebAdmin and WebService access-level users to set up basic magnetic stripe options.

Description	Default Value	Current Value (unit)	Allowed Range
1) Attempts	3	3	[1 – 5]
2) Coercivity	HICO	HICO	
3) DataFormat1	IATA	IATA	
4) DataFormat2	ABA	ABA	
5) DataFormat3	TTS	TTS	
6) NoDataDisableTrack	Disabled	Disabled	
7) ReadTrack1	Enabled	Enabled	
8) ReadTrack2	Enabled	Enabled	
9) ReadTrack3	Enabled	Enabled	
10) SSA1	0	0	[-4 – 4]
11) SSA2	0	0	[-4 – 4]
12) SSA3	0	0	[-4 – 4]
13) StripeEncoderMultiplier	1.0	1	[0.9 – 1.1]
14) WriteTrack1	Enabled	Enabled	
15) WriteTrack2	Enabled	Enabled	
16) WriteTrack3	Enabled	Enabled	

Change settings as needed, and then click **Set Current** to apply changes.

- **Attempts**—Specify the number of attempts (automatic retries) the printer makes to encode the magnetic stripe data. This value also is used for the number of times to attempt to read magnetic stripe data.

If you set this number to a lower value, it increases the throughput of the printer but can decrease the reliability of magnetic stripe encoding.

If you set the number to a higher value, it decreases the throughput of the printer but can increase the reliability of magnetic stripe encoding.

A value of 1 means no retry attempts.

- **Coercivity**—Select the coercivity setting that matches the cards you are using. Coercivity measures the resistance of magnetic material to the removal of encoded data. High coercivity (HICO) requires more electrical force to encode data and the data is more resistant to magnetic interference. The choices are **HICO**, **LOCO**, **NTT1**, **NTT2**, **NTT3**.

- **DataFormat (1, 2, 3)**—Specify the names of the data formats used for tracks 1, 2, and 3.

For single-track magnetic stripe encoding, set **DataFormat1** to **JIS** and **DataFormat2** and **DataFormat3** to **NONE**.

To use a custom data format, define the formats for tracks 1, 2, and/or 3 using the **MagStripeCustomTrack (1, 2, 3)** settings and then set the corresponding **DataFormat** settings to **CUSTOM**.

- **NoDataDisableTrack**—Disable the magnetic stripe write head for a track if the track contains no data. When this is disabled, any track that was not given data is erased.
- **ReadTrack (1, 2, 3)**—Allow magnetic stripe read actions to read from tracks 1, 2, and 3.
- **SSA (1, 2, 3)**—Set the start sentinel adjustment for tracks 1, 2, and 3. (SSA3 also sets the start sentinel for a single track.) The start sentinel is encoded on the magnetic stripe immediately before the first data character and indicates the beginning of data. Enter a value from -4 to 4.
- **StripeEncoderMultiplier**—This value is information only and cannot be changed. It is determined when an SSA test is run.
- **WriteTrack (1, 2, 3)**—Allow magnetic stripe write actions to write to tracks 1, 2, and 3.

MagStripeCustomTrack 1–3

Custom magnetic stripe settings are available for WebAdmin and WebService access-level users to define custom magnetic stripe options.

Description	Default Value	Current Value (unit)	Allowed Range
1) CustomCharHigh	Track 1: 95 Tracks 2 & 3: 63	95 63	[1 – 255]
2) CustomCharLength	Track 1: 6 Tracks 2 & 3: 4	6 4	[1 – 8]
3) CustomCharLow	Track 1: 32 Tracks 2 & 3: 48	32 48	[0 – 255]
4) CustomCharMask	Track 1: 32 Track 2: 48	32 48	[0 – 255]
5) CustomCharMax	Track 1: 76 Track 2: 37 Track 3: 104	76 37 104	[0 – 255]
6) CustomDensity	Tracks 1 & 3: 210 Track 2: 75	210 75	[0 – 255]
7) CustomEndSentinel	63	63	[0 – 255]
8) CustomLrc	EVEN	EVEN	
9) CustomParity	ODD	ODD	
10) CustomSdsNulls	0	0	[0 – 255]
11) CustomSdsRecords	1	1	[0 – 255]
12) CustomSdsSs	1	1	[0 – 255]
13) CustomStartSentinel	Track 1: 37 Tracks 2 & 3: 59	37 59	[0 – 255]

Change settings as needed, and then click **Set Current** to apply changes.

- **CustomCharHigh**—Specify the numeric value of the highest ASCII character supported for input data on the track.
- **CustomCharLength**—Set the number of bits to represent one character of data on the track, also called bits per character.
- **CustomCharLow**—Specify the numeric value of the lowest ASCII character supported for input data on the track.
- **CustomCharMask**—Specify the mask value that is subtracted from the ASCII numeric value to get the encoded value.
- **CustomCharMax**—Specify the maximum number of data characters for the track. The value does not include the start sentinel or end sentinel.
- **CustomDensity**—Specify the number of data bits per inch of magnetic stripe media for the track, also called bits per inch or bpi. Allowed values are 75 bpi or 210 bpi.
- **CustomEndSentinel**—Specify the last character encoded, which identifies the end of encoded data for the track.
- **CustomLrc**—Specify a cumulative parity bit that is encoded after the end sentinel to provide simple error checking.
- **CustomParity**—Specify a character-level parity bit encoded after each character to provide simple error checking.
- **CustomSdsNulls**—The number of nulls between each copy of the data record. You should not change this value.
- **CustomSdsRecords**—The number of times to encode the data record. You should not change this value.
- **CustomSdsSs**—The number of start sentinels before each data record. You should not change this value.
- **CustomStartSentinel**—Specify the first character encoded, which identifies the start of the encoded data for the track.

Using custom magnetic stripe data formats is a two-step process. First, define the custom tracks using **MagStripeCustomTrack1**, **MagStripeCustomTrack2**, and **MagStripeCustomTrack3**. Second, apply the custom track using the settings on the **MagStripeGeneral** menu.

1. To use the defined custom track:
 - a. Open the **MagStripeGeneral** menu.
 - b. Select Custom for **DataFormat1**, **DataFormat2**, or **DataFormat3** to use the custom track.
 - ◆ **MagStripeCustomTrack1** corresponds to **DataFormat1**
 - ◆ **MagStripeCustomTrack2** corresponds to **DataFormat2**
 - ◆ **MagStripeCustomTrack3** corresponds to **DataFormat3**
2. Click **Set Current** to apply the changes.

Laminator

The **Laminator** settings let you specify values when using a laminating system.

Description	Default Value	Current Value (unit)	Allowed Range
1) DebowDelay	1000	1000	[0 – 1500]
2) ExceptionCardDebow Direction	Down	Down	
3) ExceptionCardDebow DistanceDown	15	15	[0 – 150]
4) ExceptionCardDebow DistanceUp	105	105	[0 – 150]
5) ExceptionCardDebow DwellMs	1000	1000	[0 – 5000]
6) ExceptionCardImpress Depth	0	0	[-250 – 250]
7) ExceptionCardImpress DwellTime	2000	2000	[0 – 10000]
8) ExceptionCardImpress PositionOffset1	2000	2000	[0 – 4000]
9) ExceptionCardImpress PositionOffset2	2000	2000	[0 – 4000]

Description	Default Value	Current Value (unit)	Allowed Range
10) ExceptionCardImpress PositionOffset3	2000	2000	[0 – 4000]
11) ExceptionCardImpress Temperature	130	130	[50 – 160]
12) ExceptionCardNumber OfImpresses	1	1	[1 – 3]
13) HeaterMinutesToPower Save	15	30	[15 – 240]
14) Hopper1CardDebow Direction	Down	Down	
15) Hopper1CardDebow DistanceDown	15	20	[0 – 150]
16) Hopper1CardDebow DistanceUp	105	105	[0 – 150]
17) Hopper1CardDebow DwellMs	1000	1000	[0 – 5000]
18) Hopper1CardImpress Depth	0	60	[-250 – 250]
19) Hopper1CardImpress DwellTime	2000	2000	[0 – 10000]
20) Hopper1CardImpress PositionOffset1	2000	2000	[0 – 4000]
21) Hopper1CardImpress PositionOffset2	2000	1687	[0 – 4000]
22) Hopper1CardImpress PositionOffset3	2000	2725	[0 – 4000]
23) Hopper1CardImpress Temperature	130	155	[50 – 160]
24) Hopper1CardNumber OfImpresses	1	1	[1 – 3]
25) ImpresserSpeed	893	893	[50 – 2000]

Description	Default Value	Current Value (unit)	Allowed Range
26) L1CoolingTime	0	0	[0 – 20000]
27) L2CoolingTime	1000	1000	[0 – 20000]
28) RollerTypeInstalledL1	Standard	Standard	
29) RollerTypeInstalledL2	Standard	Standard	
30) ScanBarCodeRetries	0	0	[0 – 5]

Change settings as needed, and then click **Set Current** to apply changes.

- **DebowDelay**—Specify the amount of time (in milliseconds) to wait before the debow action takes place if the card also is being impressed. This value is valid only if an impresser is installed in the laminator. Set this value to 0 if no delay is required.

Exception Card Settings

Use the following settings when an exception job is sent. These may differ from the settings specified for cards picked from the input hopper. For example, the card material may be different or you are laminating a preprinted card. You may need to laminate multiple cards to determine the best settings to use in your environment.

Exception Card Debow Settings:

- **ExceptionCardDebowDirection**—Set the direction of the debow action in the laminator to return the card to its proper shape after an overlay is applied. A card may become bowed slightly due to heat from the laminator.
 - **Down**—The debow arms in the laminator press down on the card.
 - **Up**—The debow arms press up on the card.
- **ExceptionCardDebowDistanceDown**—Set the amount (distance) to move the debow arms down. The value is in increments of the debow motor. (This value is used when **ExceptionCardDebowDirection** is set to **Down**.)
 - Increase the value to bend the card down more.
 - Decrease the value to bend the card down less.
- **ExceptionCardDebowDistanceUp**—Set the amount (distance) to move the debow arms up. The value is in increments of the debow motor. (This value is used when **ExceptionCardDebowDirection** is set to **Up**.)
 - Increase the value to bend the card up more.
 - Decrease the value to bend the card up less.

- **ExceptionCardDebowDwellMs**—Set the time, in milliseconds, the debow action is applied to a card. The default is 2000 ms (2 seconds).
 - Increase the value to apply the debow action longer.
 - Decrease the value to apply the debow action for less time.

Exception Card Impresser Settings:

- **ExceptionCardImpressDepth**—Set the depth of the impression on a card. The value is in steps of the impresser punch.
 - Increase the value to deepen the impression.
 - Decrease the value to lessen the impression.



You may need to adjust the card impress depth value based on the card material and overlay type used.

- **ExceptionCardImpressDwellTime**—Set the time, in milliseconds, that the impresser remains in contact with the card. The default is 2000 ms (2 seconds).
 - Increase the value to allow the impresser to remain on the card longer.
 - Decrease the value to impress the card for a shorter time.
- **ExceptionCardImpressPositionOffset1**—Set the distance from the trailing edge of the card to the center of the first impression on the card.
 - Increase the offset value to increase the distance of the impression from the trailing edge of the card.
 - Decrease the offset value to decrease the distance of the impression from the trailing edge of the card.
- **ExceptionCardImpressPositionOffset2**—Set the distance from the trailing edge of the card to the center of the second impression on the card.
 - Increase the offset value to increase the distance of the impression from the trailing edge of the card.
 - Decrease the offset value to decrease the distance of the impression from the trailing edge of the card.
- **ExceptionCardImpressPositionOffset3**—Set the distance from the trailing edge of the card to the center of the third impression on the card.
 - Increase the offset value to increase the distance of the impression from the trailing edge of the card.
 - Decrease the offset value to decrease the distance of the impression from the trailing edge of the card.

- **ExceptionCardImpressTemperature**—Set the temperature of the impresser punch (in degrees Celsius).
 - Increase the value to increase the temperature of the impresser punch.
 - Decrease the value to decrease the temperature of the impresser punch.
- **ExceptionCardNumberOfImpresses**—Enter the number of impressions to be stamped on the card. The impresser can stamp up to three impressions in a row on the left, center, or right part of the card.
- **HeaterMinutesToPowerSave**—Set the number of minutes before the laminator and impresser heaters are turned off. After the specified number of minutes, the heaters are allowed to cool down. Using power save requires a warm-up period before the laminator is ready to laminate cards again. The front panel LCD displays the message **Busy Warming up** and a percentage that indicates the status of the heaters.

Hopper 1 Settings

Use the following settings to specify values for cards picked from the input hopper. Set up the input hopper for the most commonly used card type.

Hopper 1 Debow Settings:

- **Hopper1DebowDirection**—Set the direction of the debow action in the laminator to return the card to its proper shape after an overlay is applied. A card may become bowed slightly due to heat from the laminator.
 - **Down**—The debow arms in the laminator press down on the card.
 - **Up**—The debow arms press up on the card.
- **Hopper1DebowDistanceDown**—Set the amount (distance) to move the debow arms down. The value is in increments of the debow motor. (This value is used when **Hopper1DebowDirection** is set to **Down**.)
 - Increase the value to bend the card down more.
 - Decrease the value to bend the card down less.
- **Hopper1DebowDistanceUp**—Set the amount (distance) to move the debow arms up. The value is in increments of the debow motor. (This value is used when **Hopper1DebowDirection** is set to **Up**.)
 - Increase the value to bend the card up more.
 - Decrease the value to bend the card up less.

- **Hopper1DebowDwellMs**—Set the time, in milliseconds, the debow action is applied to a card. The default is 2000 ms (2 seconds).
 - Increase the value to apply the debow action longer.
 - Decrease the value to apply the debow action for less time.

Hopper 1 Impresser Settings:

- **Hopper1ImpressDepth**—Set the depth of the impression on a card. The value is in steps of the impresser punch.
 - Increase the value to deepen the impression.
 - Decrease the value to lessen the impression.



You may need to adjust the card impress depth value based on the card material and overlay type used.

- **Hopper1ImpressDwellTime**—Set the time, in milliseconds, that the impresser remains in contact with the card. The default is 2000 ms (2 seconds).
 - Increase the value to allow the impresser to remain on the card longer.
 - Decrease the value to impress the card for a shorter time.
- **Hopper1ImpressPositionOffset1**—Set the distance from the trailing edge of the card to the center of the first impression on the card.
 - Increase the offset value to increase the distance of the impression from the trailing edge of the card.
 - Decrease the offset value to decrease the distance of the impression from the trailing edge of the card.
- **Hopper1ImpressPositionOffset2**—Set the distance from the trailing edge of the card to the center of the second impression on the card.
 - Increase the offset value to increase the distance of the impression from the trailing edge of the card.
 - Decrease the offset value to decrease the distance of the impression from the trailing edge of the card.
- **Hopper1ImpressPositionOffset3**—Set the distance from the trailing edge of the card to the center of the third impression on the card.
 - Increase the offset value to increase the distance of the impression from the trailing edge of the card.
 - Decrease the offset value to decrease the distance of the impression from the trailing edge of the card.

- **Hopper1ImpressTemperature**—Set the temperature of the impresser punch (in degrees Celsius).
 - Increase the value to increase the temperature of the impresser punch.
 - Decrease the value to decrease the temperature of the impresser punch.
- **Hopper1NumberOfImpresses**—Enter the number of impressions to be stamped on the card. The impresser can stamp up to three impressions in a row on the left, center, or right part of the card.
- **ImpresserSpeed**—Set the speed of the impresser motor. The value is in increments of the motor.
 - Increase the value to increase the speed of the impresser motor.
 - Decrease the value to decrease the speed of the impresser motor.
- **L1CoolingTime**—Specify the time, in milliseconds, to wait for the card to cool after applying the overlay in the L1 laminator. The default is 0 (no delay).
- **L2CoolingTime**—Specify the time, in milliseconds, to wait for the card to cool after applying the overlay in the L2 laminator before proceeding to the L1 laminator. The default is 1000 ms (1 second). Enter 0 to turn off the delay.
- **RollerTypeInstalledL1**—Specify the type of roller installed in the L1 laminator. The options are **Standard**, **Rubber**, or **Custom**.
- **RollerTypeInstalledL2**—Specify the type of roller installed in the L2 laminator. The options are **Standard**, **Rubber**, or **Custom**.
- **ScanBarCodeRetries**—Specify the number of times the bar code scanner should attempt to read a bar code on a serialized overlay. If the read fails, the next read attempt advances the overlay to the next usable bar code on the overlay. This applies only to laminators that have the optional bar code scanner installed.

LaminateType

Use the **LaminateType** options to specify settings for the overlay materials used in the laminating system.

Description	Default Value	Current Value (unit)	Allowed Range
1) DatabaseVersion	1	13	[1 – 999]
2) ExclusiveOverlayInL1		Disabled	
3) ExclusiveOverlayInL2		Disabled	
4) OverlayDisplayed Name		0.5_mil_Clear_DG	
5) OverlayLoadedInL1 Name		0.5_mil_Clear_DG	
6) OverlayLoadedInL2 Name		Clear_Topcoat	
OverlayPartNumber	0	509065	
OverlaySpeed	160	160	[100 – 250]
OverlaySpeed AdjustmentL1	0	0	[-40 – 40]
OverlaySpeed AdjustmentL2	0	0	[-40 – 40]
OverlayTemp	160	175	[100 – 200]
OverlayTemp AdjustmentL1	0	15	[-20 – 40]
OverlayTemp AdjustmentL2	0	0	[-20 – 40]
UserOverlay1Name		None	
UserOverlay2Name		None	
UserOver3Name		None	
UserOverlay4Name		None	

Change settings as needed, and then click **Set Current** to apply changes.

- **DatabaseVersion**—The version number of the overlay database currently installed in the laminator. This field is information only. The overlay database is an XML file that contains the supported overlay types and allows the laminator to identify the type of overlay loaded in each cartridge. You can download an updated laminator supplies overlay database from the Drivers and Downloads page at www.datacard.com. The downloaded zip file contains instructions and a utility that updates the laminator.
- **ExclusiveOverlayInL1, ExclusiveOverlayInL2**—Use these settings to enforce that a specified overlay type is loaded in the L1 or L2 laminators. The default value is **Disabled**, which allows any overlay to be loaded in the laminator cartridges. If you select an overlay name, the named overlay must be loaded in the specified cartridge or the job is canceled and a supply error is issued.
- **OverlayDisplayedName**—Select the name of the overlay whose settings you want to change. Click **Set Current** to apply the overlay selection. You must do this before making any changes to the overlay settings.

The changes you make to the remainder of the settings on this page apply to the selected overlay type. The settings apply whenever the named overlay is loaded in the laminator.

- **OverlayLoadedInL1Name**—The name of the overlay type loaded in the L1 laminator cartridge. This information is obtained from the supply roll and cannot be changed. If the overlay name is the same as the overlay type selected in **OverlayDisplayedName**, the values you specify to the settings on this page apply to the overlay. If the overlay name is not the same, no changes are applied.
- **OverlayLoadedInL2Name**—The name of the overlay type loaded in the L2 laminator cartridge. This information is obtained from the supply roll and cannot be changed. If the overlay name is the same as the overlay type selected in **OverlayDisplayedName**, the values you specify to the settings on this page apply to the overlay. If the overlay name is not the same, no changes are applied.
- **OverlayPartNumber**—The part number of the overlay named in **OverlayDisplayedName**. This field is obtained from the supply roll and cannot be changed.
- **OverlaySpeed**—The default speed, in steps per second, at which to apply the overlay type named in **OverlayDisplayedName**. This value is obtained from the supply roll and cannot be changed. Make adjustments to the speed using the **OverlaySpeedAdjustment** settings.
- **OverlaySpeedAdjustmentL1, OverlaySpeedAdjustmentL2**—Adjust the speed at which to apply the overlay type named in **OverlayDisplayedName** when it is loaded in the specified cartridge. The speed adjustment is measured in steps per second of the motor that moves the card. Set the speed as the difference between the default speed value (shown in **OverlaySpeed**) and speed you want to use. Decrease the speed to improve how the overlay adheres to the card. For example, if the default is 160, and you want to set the speed to 150, enter -10.

- **OverlayTemp**—The temperature at which to apply the overlay type named in **OverlayDisplayedName**. This Current Value is obtained from the supply roll and cannot be changed. Make adjustments to the temperature using the **OverlayTempAdjustment** settings.
- **OverlayTempAdjustmentL1, OverlayTempAdjustmentL2**—Adjust the temperature at which to apply the overlay type named in **OverlayDisplayedName** when it is loaded in the specified cartridge. Enter the temperature adjustment as the difference between the Default Value and the recommended temperature obtained from the supply roll, both shown in **OverlayTemp**, to apply the selected overlay type.
 - Increase the temperature to improve how well the overlay adheres to the card.
 - Decrease the temperature to prevent wrinkling of the overlay.

Each overlay type has a preferred temperature that allows it to best adhere to the card. For example, if the default temperature is 160 degrees Celsius, and the overlay type you are using runs at 175 degrees Celsius, enter 15.



The **OverlaySpeed** and **OverlayTemp** settings work together to determine how well the overlay is applied. You might have to laminate several cards to find the speed and temperature settings that work best for your card type.

- **UserOverlay1Name, UserOverlay2Name, UserOverlay3Name, UserOverlay4Name**—These settings allow you to specify a user-defined name for an overlay type, based on the overlay named in **OverlayDisplayedName**. You then can override the settings for the specified overlay.

Update Password

WebAdmin access-level personnel can specify to password protect Printer Manager and limit access to the advanced settings. Adding password protection is the preferred method of restricting access to Printer Manager. If no password is assigned, a password is not needed to log on to Printer Manager.

Description	Value
Choose Username to Update	WebAdmin
Current Password	
New Password	
Confirm New Password	

1. Select the access level for which you want to assign a password. The WebAdmin access level can update the WebAdmin, WebUser, SnmpRwCommunity, and SnmpRoCommunity passwords.
2. Enter the current password. If a current password is not set, leave this field blank.
3. Enter the new password in the corresponding field. To remove a password, leave this field blank.
4. Enter the new password again to confirm it. Leave the field blank if you are removing the password.
5. Click **Update Password** to apply the changes.

HINTS & TIPS

- Passwords are hierarchical in the following order: WebService, WebAdmin, and WebUser. You can use a password that is higher in the hierarchy to log on to a specific role.
- Passwords may contain the following characters: a–z, A–Z, 0–9, +, and /.



Caution: Do not change the WebService password.

Set Job Queue State

Enter or select values prior to shipping the printer or system to or from repair facilities.



This setting is used primarily for financial printers. Contact your service provider for more information.

Field	Value	Description
Current Password		Enter the currently set password. Leave the field blank if no password was previously set.
Next Password		Enter a new password. A blank value means that no password is required or leaves the current password unchanged, depending on the settings.
Confirm Next Password		Retype the Next Password.
State	Online	StartJob succeeds if there is space in the queue.
	Suspend	StartJob succeeds if there is space in the queue and exceptionJob=true.
	Offline	StartJob does not succeed under any circumstances.

1. Enter the current password for the printer or system.
2. Enter a new password for the printer or system.
3. Re-enter the new password for verification.
4. Select a state:
 - **Online**—The printer performs normally.
 - **Suspend**—Deactivates the printer, but allows for some exception jobs.
 - **Offline**—Deactivates the printer for transportation.
5. Click **Set Job Queue State** to apply the changes.



To re-enable an "Offline" printer and set it back to "Online," you must enter the same password that was used to set it to "Offline."

TroubleShooting Menu

The **TroubleShooting** menu for the WebAdmin access level contains settings and tools that help you isolate card production issues. Use the TroubleShooting options to print test cards, view and print the activity log, reset the log, reset counters, and reset the printer.

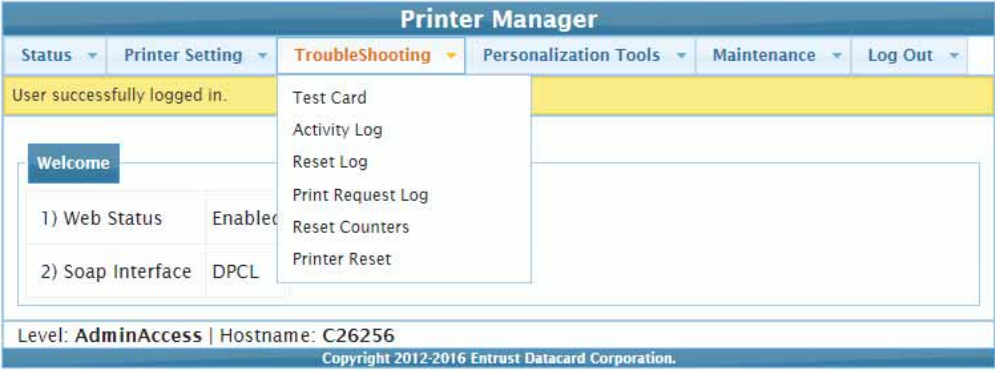

TroubleShooting Menu Option	Function	WebUser	WebAdmin
Test Card	Print test cards	No	Change all current values and run a test card
Activity Log	Display printer activity	No	View
Reset Log	Reset the activity log	No	Yes
Print Request Log	Display a log of printer requests	No	Yes (applies only to OpenCard factory-activated printers)
Reset Counters	Reset card counters	No	Yes
Printer Reset	Restart the printer	No	Yes

Test Card

The **Test Card** menu shows the items available to WebAdmin access-level users. Print test cards to troubleshoot card production issues. Select the options to test from the following.

Test Card Print Options

Description	Card Front (page 1)	Card Back (page 2)
Input Hopper Number	1	
Magnetic Stripe		[]
Magnetic Stripe JIS	[]	
Color	[]	[]
Monochrome	[]	[]
Topcoat	[]	[]
Second Topcoat	[]	[]
Test Pattern to use for Color and/or Monochrome	[TestPattern1]	[TestPattern1]
Lamination Options	None	
Debow	[]	
Impress	[]	

Test Card Other Options

Description	Current Value (unit)	Allowed Range
Copies	1	[1 – 10]
Park Smart Card	[]	
Smart Card Park Time	10 seconds	[0 – 300]
Do not eject card	[]	

Enter the value(s) for the type of test card to print, and then click **Run** to send the test card to print.

- **Input Hopper Number**—Select the input hopper from which the test card should be picked.
- **Magnetic Stripe**—Print the test card with encoded magnetic stripe data.
- **Magnetic Stripe JIS**—Print the test card with encoded JIS magnetic stripe data.
- **Color**—Print the test card using the YMCK panels of the print ribbon on the front or back.
- **Monochrome**—Print the test card using a monochrome ribbon (or the K panel of a color ribbon) on the front or back.
- **Topcoat**—Print the test card with topcoat on the front or back.
- **Second Topcoat**—Print the test card with a second topcoat on the front or back.
- **Test Pattern to use for Color and/or Monochrome**—Select the type of test pattern to use on the front or back of the test card. You can select from the following:
 - **TestPattern1**—Use this test to evaluate the overall print quality of the card. The color test prints a full-color test card using the YMCK panels of the print ribbon. The monochrome test card prints several lines of text.
 - **TestPattern2**—Use this test to evaluate the overall print quality when using short-panel color print ribbon. The monochrome test card prints several lines of text.
 - **TestPattern3**—Use this test to identify print intensity issues that can appear as wrinkles on the printed card. The color test prints a dense blue color card to test the density of the printed card. The monochrome test card prints a calibration grid.
 - **TestPattern4**—Use this test to print a color-step test card that uses all panels of the print ribbon and displays the steps of each color from darkest to lightest. The monochrome test card prints a calibration grid.
 - **TestPattern5**—Use this test to set up the card registration of the printer. Print the card to verify changes to the card registration settings. The monochrome test card prints a calibration grid.
 - **TestPattern6**—Use this test to print a marbles-image color test card to evaluate general appearance. The monochrome test card prints several lines of text.
 - **TestPatternRegistration** and **TestPatternChecked**—Use these tests to check card registration mechanically. Side/side or lead/trailing issues may indicate a chassis, card guide, or roller problem. The monochrome test card prints several lines of text.
 - **TestPatternShort**—Use this test to print a short-panel ymckT test card. The monochrome test card prints text on the card.
 - **TestPatternGrid**—Use this test to print a full K panel test card.

- **TestPatternPaleBlue**—Use this test to identify print intensity issues that can appear as wrinkles on the printed card. This option prints a lighter blue color card than TestPattern3. The monochrome test card prints several lines of Katakana text on the card.
 - **TestPatternManufacture A–E**—These test cards are used only during manufacturing setup.
- **Lamination Options**—Use this test to determine whether a laminator system is applying overlay material properly. You can select from the following lamination options:
 - **L1 Front**—Applies overlay from the L1 laminator to the front of the card.
 - **L1 Back**—Applies overlay from the L1 laminator to the back of the card.
 - **L1 Front L1 Back**—Applies overlay from the L1 laminator to the front and back of the card.
 - **L2 Front**—Applies overlay from the L2 laminator to the front of the card.
 - **L2 Back**—Applies overlay from the L2 laminator to the back of the card.
 - **L2 Front L2 Back**—Applies overlay from the L2 laminator to the front and back of the card.
 - **L2 Back L1 Front**—Applies overlay from the L2 laminator to the back of the card, and overlay from the L1 laminator to the front of the card.
 - **L2 Front L1 Back**—Applies overlay from the L2 laminator to the front of the card, and overlay from the L1 laminator to the back of the card.
- **Debow**—Select this option to apply the debow action when an overlay is applied to the card.
- **Impress**—Select this option to impress a card, if an impresser is installed.
- **Copies**—Enter the number of test cards to print for each test, from 1 to 10.
- **Park Smart Card**—Select this option to park the test card in the smart card bay. The test does not transmit any data, but is used to test the movement of the card into, and out of, the bay.
- **Smart Card Park Time**—Enter the amount of time to hold the test card in the smart card bay, from 0 to 300 seconds.
- **Do not eject card**—Select this option to prevent the test card from being ejected from the printer.

Activity Log

The **Activity Log** displays information about printer activity. It includes all actions and errors since last reset. Save and send the activity log to your service provider when you request service. The log provides valuable information for troubleshooting printer performance issues.

1. Click **Download** to save the activity log information.
2. Enter a location on your PC to save the file.
3. Save and send the activity log to your service provider when you request service.

Sample Data

```
12: 0d 00h 00m 25.202s [SYSTEM__CRIT ] value of flip det <1> value of opt board det <1>
value of punch det <0> in printer.cpp
```

```
14: 0d 00h 00m 25.196s [SYSTEM__WARNING] Improper shutdown detected
```

```
14: 0d 01h 10m 14.135s [JOB____NOTICE ] Resolved condition 1-JobFailed Notice 637/638
"hostname".770962.0.0
```

Reset Log

The **Reset Log** option allows a WebAdmin access-level user to reset the Activity Log.

Click **Run** to reset the Activity Log.

Print Request Log

The **Print Request Log** option allows a WebAdmin access-level user to view and reset the Print Request Log.



This option applies only to OpenCard factory-activated printers.

Select the Number of Logs (5, 10, 15, 20, 25, or All) and click **Run** to view a log of the print requests sent to the printer.

To reset the audit log, click **Run** in the **Reset Log** field.

Reset Counters

The **Reset Counters** option resets the Current Card counter functions in the printer. Life counters or total card counts cannot be reset.

Click **Run** to reset the counters.

Printer Reset

The **Printer Reset** option restarts the printer.

Click **Run** to restart the printer.

Personalization Tools Menu

The **Personalization Tools** menu allows WebAdmin access-level users to import, export, and delete card formats, fonts, and images used with some software personalization tools, such as OpenCard. Refer to the *SD/CD Series Card Printers OpenCard Data Format Guide* for additional information.

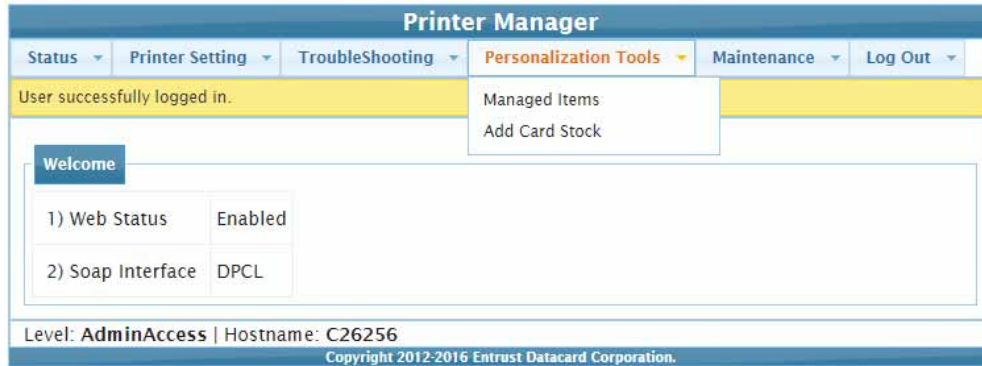

Personalization Tools Menu Options	Function	WebUser	WebAdmin
Managed Items	Display managed items	No	List, Add or Delete Managed Items
Add Card Stock	Add card stock	No	Add Card Stock Name

Managed Items

Select Card Format, Images, Card Stock, Fonts, or Font Families and click **List Items** to display the current list of loaded files for the selected group.

- To add an item to a selected group, click **Browse**, select a file path, and click **Add Item**.
- To remove a loaded file, select a file in the list of loaded files and click **Delete Item**.
- To export an item to your PC, select the item to export and click **Export Item**. Specify a location for the exported item.

Add Card Stock

1. Type a name for the card stock in the Card Stock Name dialog.
2. Click **Add** to load a card stock.

Maintenance Menu

The **Maintenance** menu allows WebUser and WebAdmin access-level users to run a cleaning card from Printer Manager. Additionally, the Maintenance menu provides the WebAdmin level with the rights to upload updates to the printer.

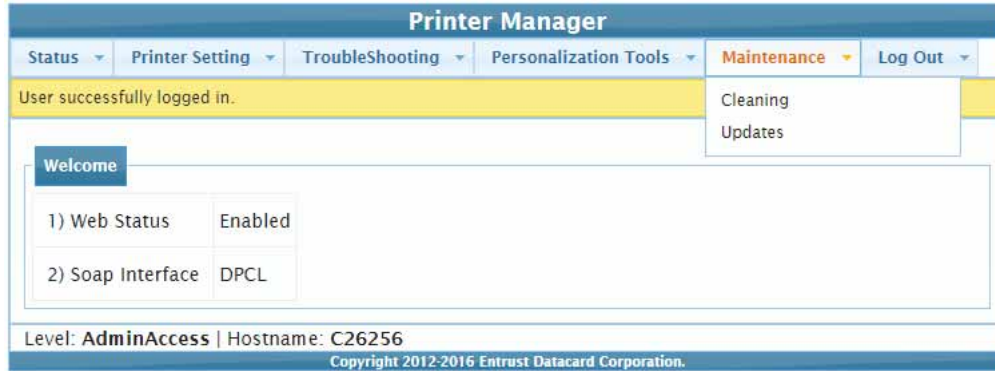

Maintenance Menu Option	Function	WebUser	WebAdmin
Cleaning	Clean the printer, hoppers (for printers with the optional multi-hopper), or laminator	Run Card	Run Card
Updates	Update the printer settings	No	Upload File

Cleaning

Cleans the printer using a cleaning card. If the printer has the optional multi-hopper, you also can clean the hopper rollers on all the hoppers or select individual hoppers for cleaning. If the printer has a laminator, you also can select to clean the laminator.

Clean the Printer

1. Unlock the system, if necessary.
2. Remove the supplies.
 - a. Open the printer's top cover and remove the ribbon cartridge.
 - b. Remove the print ribbon, if necessary.
 - c. Remove the cleaning sleeve.
 - d. Replace the ribbon cartridge.
 - e. Remove any blank card stock from the input hopper.

- f. Close the printer cover.
 - g. Lock the printer.
3. Place the unwrapped cleaning card in the card input hopper. If your printer has the optional multi-hopper, place the cleaning card in hopper 2.
4. Select **Maintenance > Cleaning**.
5. Select **Clean Printer**.
6. Click **Run** to start the cleaning process. Press the USER button on the printer when the message "172: Insert cleaning card" displays on the LCD panel.

The printer picks the cleaning card, moves it through the printer several times, and ejects it in the output hopper or card reject tray.
7. Remove the used cleaning card. Wait a few minutes for the rollers to dry.
8. Replace the supplies.
 - a. Place the cards in the input hopper.
 - b. Replace the print ribbon, if necessary.
 - c. Replace the cleaning sleeve with a new sleeve and remove the protective cover.
 - d. Replace the ribbon cartridge and close the printer cover. Lock the printer, if necessary.

Clean the Multi-Hopper

1. Unlock the printer and open the multi-hopper cover.
2. Remove any blank card stock from the hoppers.
3. Open the cleaning card package and insert the cleaning cards into the hoppers you plan to clean.
4. Close the multi-hopper cover.
5. Select either **Clean All Hoppers** or **Clean Hopper** and select the number of the hopper you want to clean.
6. Click **Run** to start the cleaning process. Press the USER button on the printer when the message "172: Insert cleaning card" displays on the LCD panel.

The cleaning cards are moved back and forth across the hopper rollers several times and then ejected back into the hoppers.
7. Open the multi-hopper door and remove the cleaning cards.
8. Replace the card stock in the hoppers and lock the printer.

Clean the Laminator

1. Select **Clean Laminator** on the **Maintenance > Cleaning** page.
2. Click **Run**.

The printer LCD panel displays the message "172: Insert cleaning card."

3. Insert the laminator cleaning card into the card exit slot of the laminator and press the USER button.

The laminator pulls the cleaning card from the card exit slot into the laminator and moves it back and forth through the L1 and L2 cartridge areas and the card entry area several times. The used card is ejected into the laminator output hopper.

Updates

The **Updates** option allows a WebAdmin access-level user to send an external settings file to the printer.

To upload a settings file:

1. Click **Browse** and select the file to upload.
2. Click **Upload File**.

Log Out Menu

Use the **Log Out** option to end the current Printer Manager session and return to the Printer Manager Log In page. For security, close the browser window after you log out.

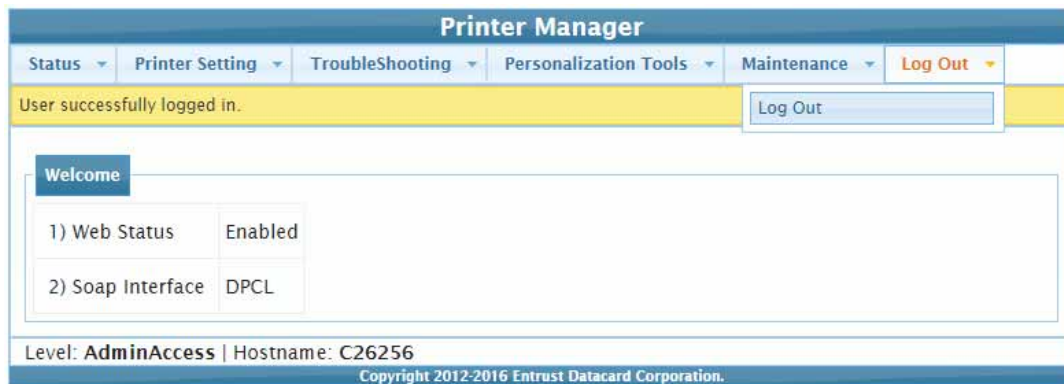

Log Out Menu Option	Function	WebUser	WebAdmin
Log Out	Log out and return to the Log In page	Yes	Yes



Chapter 4: Supplies and Parts

4

This section describes the supplies and parts for the printer. It includes:

- [Print Ribbon on page 98](#)
- [Laminator Supplies on page 102](#)
- [Cards on page 105](#)
- [Cleaning Supplies on page 107](#)
- [Replacement Parts on page 108](#)
- [Optional Equipment on page 109](#)
- [Cables and Power Supplies on page 110](#)

Print Ribbon

Print ribbon kits are available from your dealer. Kits include a print ribbon, a cleaning card, and a replaceable cleaning sleeve. For best results, run a cleaning card and replace the cleaning sleeve with each new print ribbon.



The first time a color ribbon with a region code is installed in the printer, the printer is assigned to the region and must use supplies with the correct region code. The region code displays on the printer LCD panel. Contact your dealer for complete information about region codes, and to order the correct regional supplies for your printer.

Color Print Ribbon

Color print ribbon is available in either full-panel or short-panel options. Both full-panel and short-panel print ribbons use the following color panels: Y (yellow), M (magenta), C (cyan/blue), K (black), and T (topcoat). Ribbons with an ultraviolet fluorescent (F) panel provide an additional security feature. Ribbons without a T (topcoat) panel are available for laminating printers.

Full-Panel Color Print Ribbon

Use full-panel print ribbon when the card design calls for color printing on the entire card.

Full-panel color print ribbons with an ultraviolet (UV) fluorescent panel, YMCKF-KT and YMCKFT, also are available.

Full-panel YMCKT Ribbon



YMCKF-KT Ribbon



The ribbon panel configuration that supports YMCKFT functionality can differ depending on your printer model.

Short-Panel Color Print Ribbon

Use short-panel print ribbon when only a portion of the card design calls for color. For example, a card design may have a color photo on the top or left of the card, and black text on the bottom of the card. The color area for short-panel ribbon is 1.57 inches (40 mm) or 1.47 inches (37.5 mm), depending on the ribbon configuration. The ymc panels of short-panel ribbon are approximately half the length of a full card.

Short-panel ymckT Ribbon



When you print with short-panel print ribbon, you define the location of the color area in the card design. Color printing begins when the software detects a color pixel and continues for the length of the ymc panels.

Color Print Ribbon Kits

The following color print ribbon kits are available.



Some of the ribbons in the following list do not have a region code and can be used in any printer. Contact your dealer for more information and to order supplies.

- YMCKT Color Ribbon, 250 images per roll
- YMCKT Color Ribbon, 500 images per roll
- ymckT (short-panel) Color Ribbon, 650 images per roll
- YMCKT-K Color Ribbon, 375 images per roll
- YMCKT-KT Color Ribbon, 300 images per roll
- ymckT-KT (short panel) Color Ribbon, 435 images per roll
- YMCKFT Color Ribbon with UV, 300 images per roll
- YMCK Color Ribbon, 500 images per roll (laminating systems only)
- YMCK-K Color Ribbon, 500 images per roll (laminating systems only)
- YMCKF-KT Color Ribbon with UV, 300 images per roll (laminating systems only)

Monochrome Print Ribbon

A monochrome ribbon prints the entire card in one color.



Monochrome ribbons do not have a region code and can be used by all printers.

Monochrome ribbon can be:

- Alternating black and topcoat panels (KT or KTT ribbon)
- Continuous black (K ribbon)
- A continuous color, such as red or silver
- Silver with Topcoat, Black with Topcoat (ST-KT)
- Gold with Topcoat, Black with Topcoat (GT-KT)

Monochrome Print Ribbon Kits

The following monochrome print ribbon kits are available:

- Alternating black and topcoat panels (KT ribbon), 1000 images per roll
- Black with two topcoat panels (KTT ribbon), 750 images per roll

The printer applies black and two topcoat panels on the same side of the card.

KT Ribbon



KTT Ribbon



The KTT ribbon type is not supported in OpenCard-enabled systems. It uses only one T panel, instead of both.

- Continuous black (K ribbon), up to 500 images per roll
- Continuous black (K ribbon), up to 1500 images per roll
- Continuous dark blue, up to 1500 images per roll
- Continuous white, up to 1500 images per roll
- Continuous red, up to 1500 images per roll
- Continuous green, up to 1500 images per roll
- Continuous silver, up to 1500 images per roll
- Continuous gold, up to 1500 images per roll
- Continuous silver metallic, up to 1500 images per roll
- Continuous gold metallic, up to 1500 images per roll
- Continuous scratch-off, up to 1500 images per roll
- Monochrome-Topcoat, Black-Topcoat:
 - Silver-Topcoat, Black-Topcoat, up to 500 images per roll
 - Gold-Topcoat, Black-Topcoat, up to 500 images per roll



ST-KT Ribbon



GT-KT Ribbon



These ribbons print the front side of the card using the monochrome color panel and the back side using the black (K) panel. Topcoat can be applied on one or both sides.

Ribbon Saver

A roll of Datacard-certified monochrome ribbon enables the Ribbon Saver feature in the printer. Ribbon Saver can increase the number of cards printed with each roll of ribbon because only the printed portion of the ribbon is used. Excess ribbon is not advanced, reducing waste.

Print Ribbon Storage Guidelines

- Store print ribbon in the original package until you load it in the printer. Keep the original packaging closed until you are ready to use the ribbon.
- The print ribbon maintains its quality for about one year. For optimum card quality, purchase and store quantities of print ribbon that can be used within one year.
- The print ribbon and card stock might require secure storage and tracking. Follow your organization's policy for storing and tracking the supplies used to make cards.
- Store the print ribbon in a location away from direct sunlight, with a temperature between 32° and 77°F (0° and 25°C). A range of 40% to 60% non-condensing humidity is recommended.
- Install supply rolls at room temperature. If supplies are stored in an environment that is cooler than the printer environment, allow supplies to reach room temperature before you use them.
- If the printer will not be used for an extended period, remove supplies from the printer and store them with new supplies.

Laminator Supplies

The laminator applies topcoat or patch overlay material to the front and back of the card. Topcoat is a continuous film and patch is a die-cut polyester shape designed to fit standard ISO ID-1 size card stock.

Topcoat and Patch Overlays

A patch overlay can cover the complete card, can have an opening for a smart card chip, or can cover the card under the magnetic stripe.

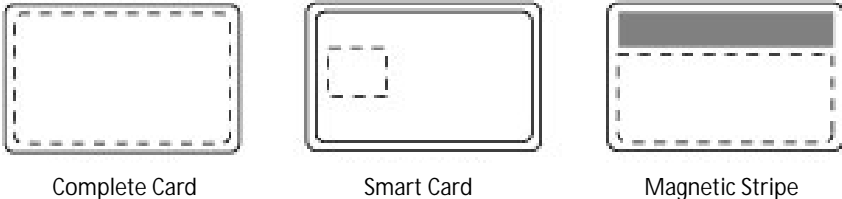

Complete Card

Smart Card

Magnetic Stripe

Both topcoat and patch overlays can be clear or can have a transparent holographic image on them. The holographic materials are called holographic topcoat or holographic patch and also can be ordered with a custom image. In addition, holographic topcoat or patch can be designed with a registered image that is located in the same position on each card.

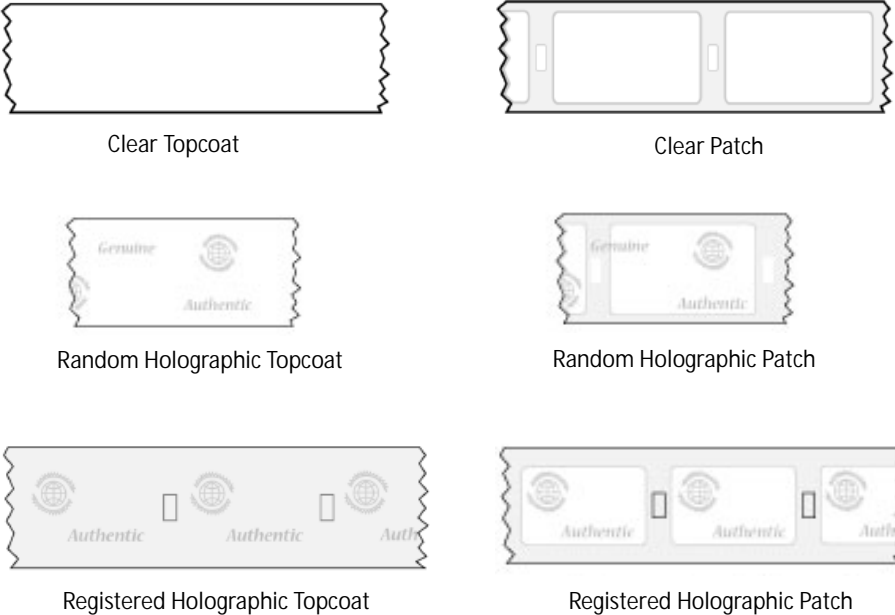

Clear Topcoat

Clear Patch

Random Holographic Topcoat

Random Holographic Patch

Registered Holographic Topcoat

Registered Holographic Patch

The following laminator supplies are available. Most are available for a full card, smart card, or magnetic stripe card.

Patch:

- Clear DuraGard®, 0.5 mil, up to 350 images/roll
- Clear DuraGard, 1.0 mil, up to 300 images/roll
- Holographic DuraGard 0.6 mil, Random, up to 350 images/roll
- Holographic DuraGard, Registered, 0.6 mil, up to 350 images/roll
- Holographic DuraGard, 1.0 mil, Random, up to 300 images/roll
- Holographic DuraGard Registered, 1.0 mil, up to 300 images/roll
- Holographic DuraGard, Registered, Serialized, 1.0 mil, up to 300 images/roll



Caution: DuraGard patch overlay cannot be applied over a “T” panel topcoat applied from a ribbon. Make sure that the DuraGard patch is applied to the card side without a “T” panel topcoat.

Topcoat:

- Clear, number of images depends on lamination settings
- Holographic, Random, number of images depends on lamination settings
- Registered Holographic, up to 600 images/roll
- Clear DuraShield™, number of images depends on lamination settings (see note)
- Holographic DuraShield, Random, number of images depends on lamination settings (see note)
- Holographic DuraShield, Registered, 500 images/roll (see note)



DuraShield clear and holographic overlays must be used with a ribbon that includes an inline topcoat (T) panel, for example, KT, YMCKT, YMCKT-K, YMCKT-KT, ymckT, or YMCKF-KT. It must be applied over the topcoat.

Overlay Storage Guidelines

- Store overlay material in the original package until you load it in the laminator. Keep the original packaging closed until you are ready to use the overlay.
- The overlay maintains its quality for about one year. For optimum card quality, purchase and store quantities of material that can be used within one year.
- Overlay material might require secure storage and tracking. Follow your organization's policy for storing and tracking the supplies used to make cards.
- Store the overlay in a location away from direct sunlight, with a temperature between 50° and 80°F (10° and 27°C). A range of 30% to 70% humidity is recommended.
- Install supply rolls at room temperature. If supplies are stored in an environment that is cooler than the printer environment, allow supplies to reach room temperature before you use them.
- If the printer will not be used for an extended period, remove supplies from the printer and store them with new supplies.

Cards

For best results, use high-quality cards that meet the specifications and recommendations described in this section.

Card Size

Use ISO ID-1 cards, also called CR80 cards. The cards have the following dimensions:

Length	3.37 inches	85.60 mm
Width	2.125 inches	53.98 mm
Thickness	0.010 to 0.030 inches	0.254 to 0.762 mm

Actual card thickness can vary by up to ten percent from the sizes listed. The card bow must be less than the thickness of the card.

Card Material

Use cards with a glossy PVC surface, either 100% PVC cards or composite cards with a PVC surface. Cards can have a magnetic stripe on one side of the card.

Pre-Punched Cards

For best results, punch cards after printing them. The cards can have a punched area within 1 inch (25 mm) of the left edge, as the cards are loaded in the printer. If the card has a magnetic stripe, the card cannot be punched anywhere in the stripe.

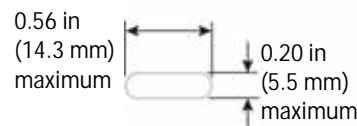

New Cards for Color Printing

The printer is designed to print on new card stock. If you print on cards twice, be careful to avoid getting dirt, fingerprints, or other contaminants on cards before the second printing. Previous printing can interfere with printing and result in cards that do not have the appearance you want. Printing on cards that previously have been issued might introduce substances that interfere with card printing or damage the printer. If a previously printed card has been printed with topcoat, the card cannot be printed a second time.

Adhesive-Backed Cards

Adhesive-backed cards are printed, and then adhered to contactless smart cards when the card surface is not flat enough to print. Use only Datacard adhesive-backed cards with the printer. The printing surface (white side) of an adhesive-backed card meets the material requirements for use in the printer. Use the following guidelines:

- Store cards in a cool place (such as a refrigerator) to avoid adhesive migration.
- Clean the printer's card tracks to remove any adhesive residue. Use a printhead cleaning swab or isopropanol and a swab to remove the residue.
- Use a print margin of at least 0.05 inch when using adhesive-backed cards.
- Do not apply laminator overlay material to adhesive-backed cards.

Card Quality Guidelines

Cards must meet the following card quality guidelines for the printer to print high-quality graphics on them successfully.

Card Surface

The card must be smooth and even, and free of irregularities such as raised burrs or particles embedded in the surface. Surface irregularities can cause printing voids, especially when printing edge to edge.

Card Handling

These guidelines apply to unprinted cards.

- Any debris or particles on the surface of an unprinted card can reduce print quality and damage the printhead.
- Grease or oils, such as oils from your fingers, also reduce print quality. Keep cards completely clean. Do not touch the print surface of a card with your fingers or hands. Handle blank card stock by the edges only or wear gloves.
- Do not use a rubber band to bind blank cards together.
- If you drop a card on the floor, do not insert it into the printer.

Card Storage

These guidelines apply to both printed and unprinted cards.

- Cards must be stacked so that they do not shift and rub against each other.
- When you store cards, make sure that no two cards contain images or blocks of color that come in contact with each other.
- Make sure that the magnetic stripe on one card does not come in contact with the magnetic stripe on another card.
- Make sure that cards with magnetic stripes are stored away from magnets and other magnetic objects.
- Store cards in a cool, dry, and dark place. Excessive light can cause yellowing of cards on exposed edges.
- Keep cards in their original packaging.
- Cards must be at room temperature when they are used. If cards are stored in a cooler environment than the printer, allow them to reach room temperature before you use them.

Cleaning Supplies

The print ribbon kit includes a cleaning card and a replaceable cleaning sleeve. For best results, keep additional cleaning supplies on hand.

The following additional cleaning supplies are available:

Supply	Description
Printer cleaning cards	Pack of 10 double-sided, isopropanol-coated cleaning cards used to clean the printer card track and transport rollers.
Cleaning sleeves	Pack of 5 replaceable, adhesive-coated cleaning sleeves.
Cleaning swabs	Pack of 5 isopropanol-saturated cleaning swabs to clean debris and dust from the printhead and from hard-to-reach internal areas of the printer.
Laminator cleaning cards	Pack of 10 double-sided, sticky cleaning cards used to clean the laminator when a holographic overlay is installed.

Replacement Parts

The following replacement parts are available.

Printhead Cartridge

The printer has a replaceable printhead cartridge. The printhead is subject to wear or damage and has a direct impact on print quality.

Do not touch the printing edge of the printhead in the printhead cartridge. Clean the printhead following the steps in your printer's *User's Guide*.

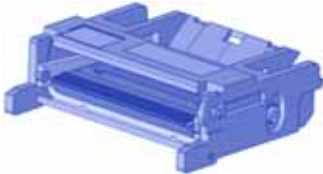

Print Ribbon Cartridge

The ribbon cartridge holds the print ribbon and the replaceable cleaning sleeve in the printer.



Cleaning Roller Spindle

The cleaning roller spindle holds the replaceable cleaning sleeve.

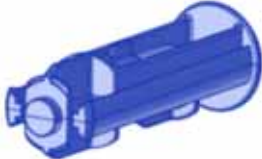

Laminator Cartridges

The green L1 and orange L2 cartridges hold the laminator overlay material. They are used in the optional CLM laminator only.

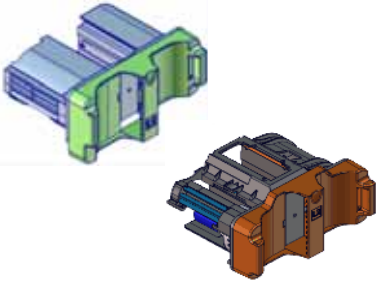

Impresser Die

Contact Entrust Datacard to special-order a new die for your impresser. The die must be installed by an authorized Entrust Datacard service provider.



Optional Equipment

The following optional equipment is available.

Large Output Hopper

The printer can use a large output hopper, which holds about 100 cards. You can replace the small, standard hopper with the large hopper without using tools.

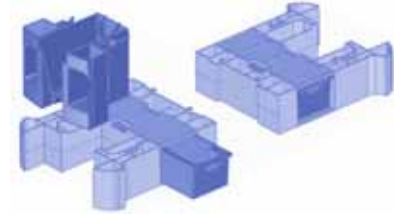

200-Card Input Hopper

The 200-card input hopper kit includes the larger hopper with an attached cover. The standard hopper is easily removed and the 200-card hopper can be installed without using tools.

Cable Lock

The printer can be used with a cable lock. Obtain the lock from your dealer, because it includes an added security plate that is inserted into the printer.

Cables and Power Supplies

The printer uses the following cables and power supplies.

Data Cables

The data cable connects the printer to the network or directly to a PC. You can use one of the following data cables:

- USB
- Network (Ethernet)

Use only one type of data cable with a printer. If you need to connect more than one PC to a printer, use a network connection.

USB Cable

Use a USB data cable, 6 feet (2 meters) long, to connect the printer to the PC. Be sure to use a cable rated for USB 2.0 data transmission.



Network Cable

Use a standard Ethernet network cable, also called a Category 5 or Cat 5 cable, to connect the printer to a network port.



Ethernet cables are not available from Entrust Datacard. You can purchase a cable from a third-party supplier.

USB Smart Card Cable

Printers that have a loosely coupled smart card reader use a USB data cable, up to a maximum of 6 feet (2 meters) long, to connect the smart card reader in the printer to the PC.

Power Supplies

You can order the following power supplies:

- Printer—the printer power supply is rated as follows:
 - Input: 110–240V, 50–60Hz, 1.5A
 - Output: 24V, 3.0A, 72W

It is self-adjusting within the rated input voltage.



- Laminator—the laminator power supplies are rated as follows:

- Laminator with L1 only:
 - ◆ Input: 100–240V, 47–63Hz, 2.2A
 - ◆ Output: 24V, 3.75A, 90W
- Laminator with L1 and L2:
 - ◆ Input: 100–240V, 47–63Hz, 2.2A
 - ◆ Output: 24V, 6.6A, 160W



Laminator power supplies are self-adjusting within the rated input voltage

Power Cords

You can order power cords for the following:

- Printer—The printer power cord connects the printer power supply to the facility power. Be sure to use a cord that grounds to the facility power source.
- Laminator—The laminator power cord connects the laminator power supply to the facility power.

The printer and laminator can use one of the following country-specific power cords:

- USA power cord
- Australia power cord
- Brazil power cord
- China power cord
- Denmark power cord
- European power cord
- India power cord
- Israel power cord
- Italy power cord
- Japan power cord
- South Africa power cord
- Swiss power cord
- United Kingdom power cord





Appendix A: CLM Laminator

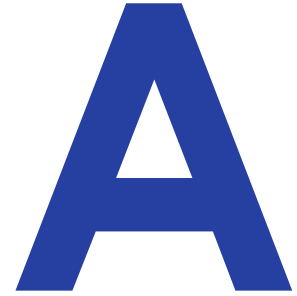

This appendix provides information about the optional CLM laminator that you can add to your system at the time of purchase or later, as a field upgrade.

About the Laminator System

A laminator system consists of a CD800 card printer and a CLM laminator. The system can print cards and apply an overlay material on the front and back of the card for increased durability and security. Using an overlay material with holographic or other transparent images also improves the security of the card. These materials are tamper evident, making it difficult to reproduce or modify a card.

 Your laminator may look different from the one shown in the illustrations, based on the options installed. The procedures described in this appendix apply to all CLM laminators.

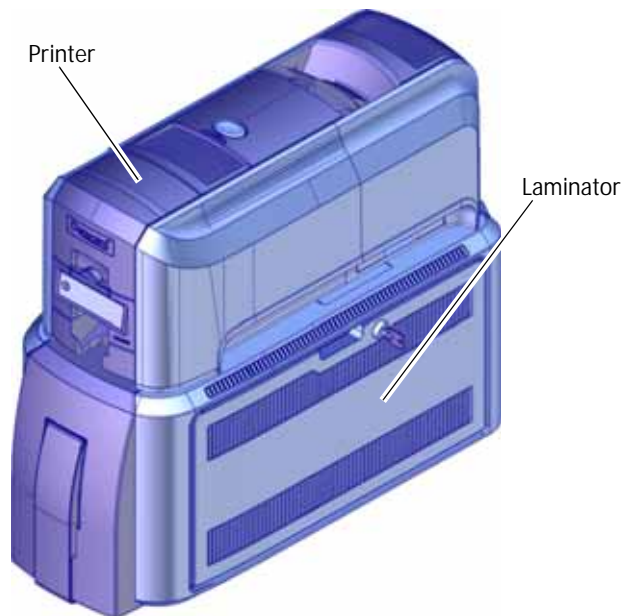

Site Requirements

Provide space for the system and for clearance around the system. Refer to "Site Requirements" on page 3 for information about selecting a location for the system.

System Dimensions

The external system dimensions are shown in the following illustration.

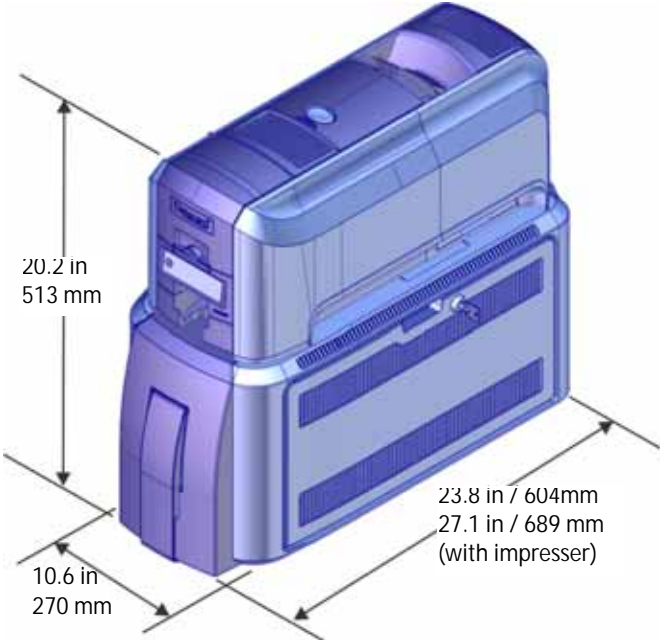

Clearance Requirements

The following measurements show the system dimensions when the input hopper, printer cover, and laminator access doors are open.



We recommend that you provide a minimum of 3 inches (76.2 mm) of additional clearance around the system to maintain access to the power cord and data cables, to load and remove cards and supplies, and to provide ventilation.

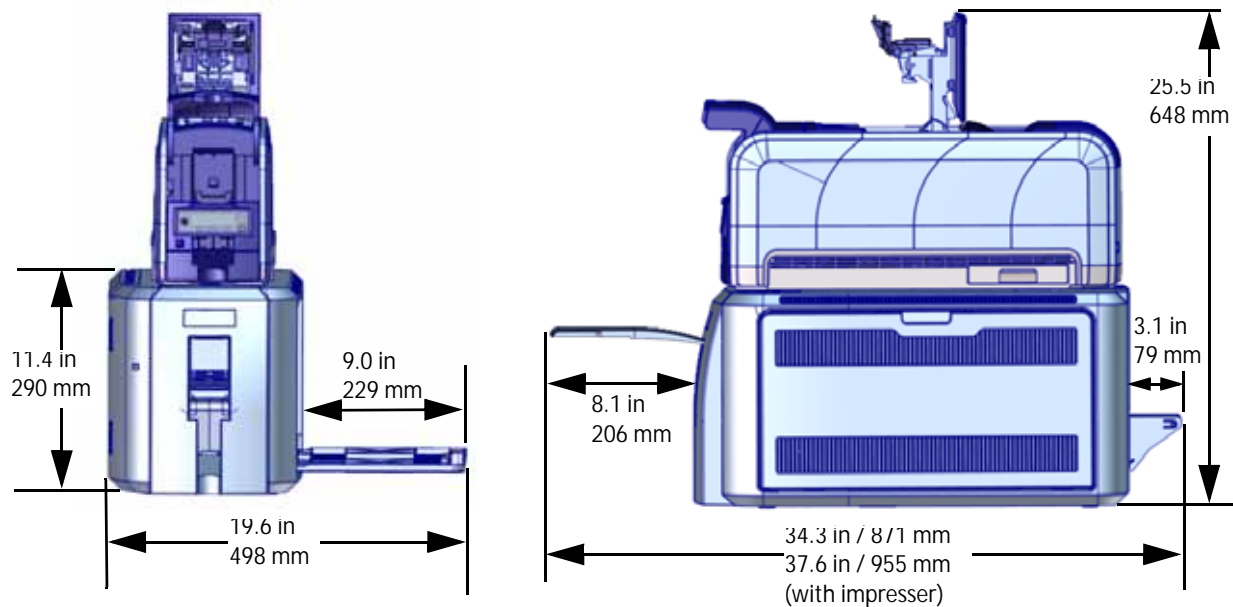

Electrical Requirements

The power supply is rated as follows:

System Component	Electrical Requirements	
	Input	Output
Printer	110–240V/50–60 Hz/1.5 Amp	24V/3.0Amp/72W
Laminator with L1 only	100–240V/47–63 Hz/2.2 Amp	24V/3.75Amp/90W
Laminator with L1, L2, and impresser	100–240V/47–63 Hz/6.6 Amp	24V/6.6Amp/160W

Unpack the System

Remove the printer and laminator from their shipping cartons.

1. Open the printer shipping carton and remove the printer and its accessories.
2. Open the laminator shipping carton and remove the accessories boxes.

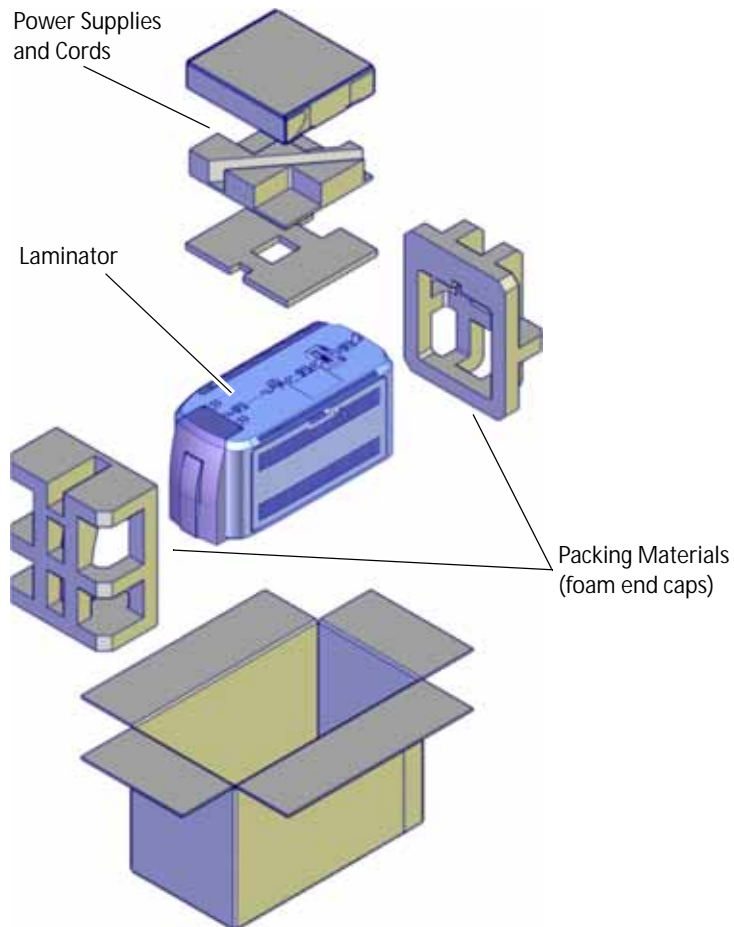

3. Lift the laminator from the carton and remove the foam end caps.
4. Place the laminator on a surface that meets the requirements specified in [“Site Requirements”](#) on page A-2.
5. Secure the laminator, if necessary. Refer to [“Bolt-Down Option”](#) on page A-5.



Save the shipping cartons and packing materials. They are required if you need to store, move, or return the system for service.

Bolt-Down Option

The laminator includes bolt-down openings that you can use to secure the system to a mounting surface.

 This procedure is optional.

You need the following supplies:

- The bolt-down kit (part no. 509169-001) contains two M6 well nuts.
- Two M6 (6 mm) screws, purchased separately.

The length of the screws you need depends on the thickness of the mounting surface. The screw length is the surface thickness + 0.75 inch (20 mm).

- Two M6 washers, purchased separately.
- 1/4-inch (7 mm) drill bit.

1. Drill two holes in the mounting surface following the dimensions and requirements shown in the following figure:

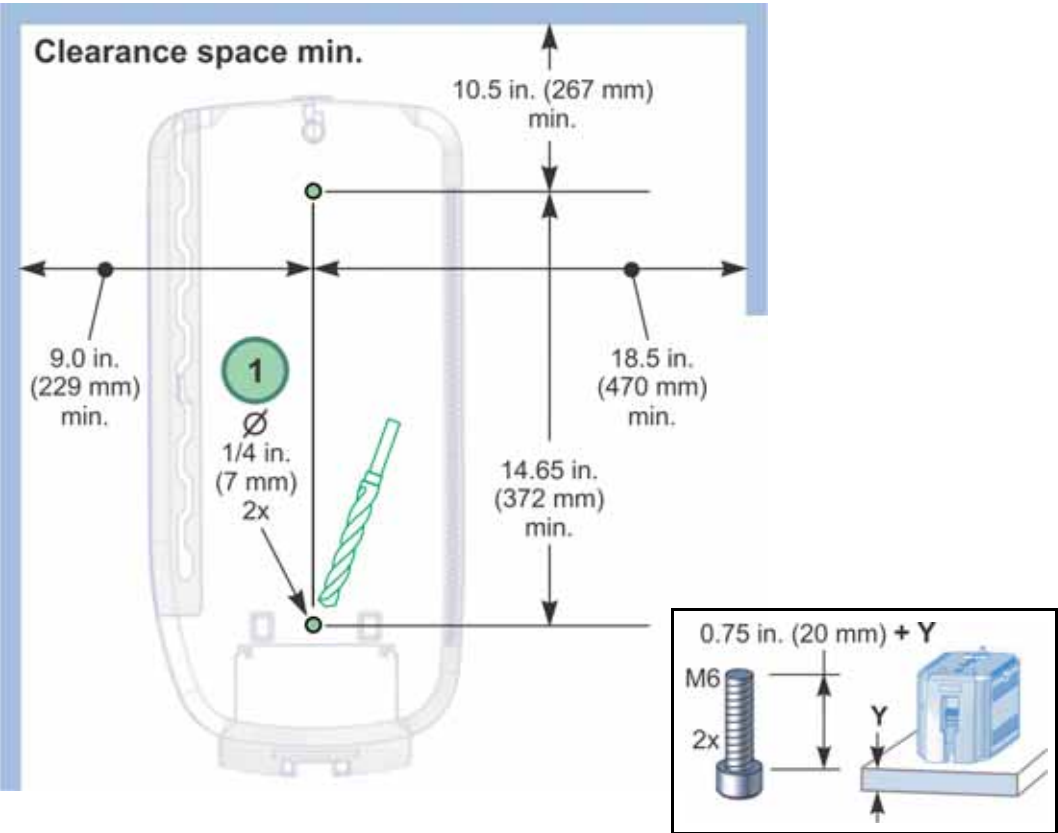

2. Carefully tip the laminator onto its left side (the side without the access door).
3. Insert the M6 well nut threaded inserts into the bolt-down openings on the bottom of the laminator.
4. Return the laminator to its upright position and position it over the holes that are drilled in the mounting surface.
5. Secure the laminator to the mounting surface.
 - a. Place a flat washer on each of the screws beneath the mounting surface.
 - b. Insert the M6 screws through the holes in the mounting surface and into the well nuts in the bottom of the laminator.
 - c. Tighten the screws securely.

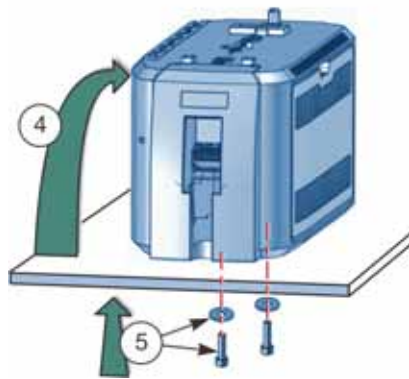
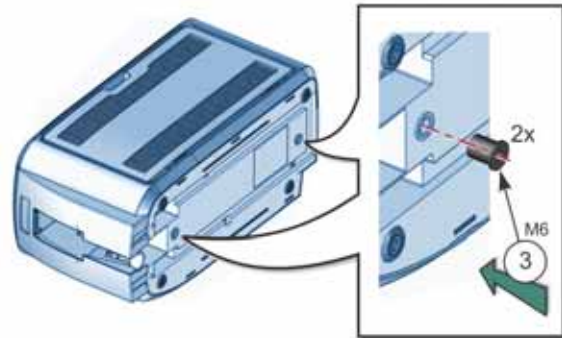
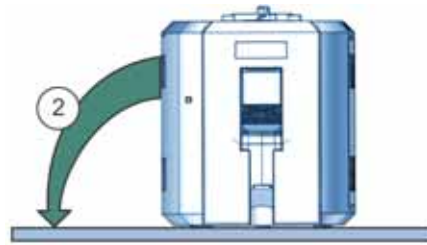

Prepare the Printer

Do the following steps to prepare the printer to connect to the CLM laminator.



- You cannot attach a printer with a multi-hopper to the laminator.
- If you have installed a large output hopper on the printer, you must remove it before connecting the printer to the laminator.

Remove, Replace, or Modify the Reject Tray

The reject tray must be removed, replaced, or modified to allow a card traveling through the printer to enter the card transfer area of the laminator.

CD800 Printers Without Locks

1. Remove the reject tray from the printer. Keep the tray in a safe place in case you need to return it to the printer in the future.
2. Continue with [“Remove the Interconnect Port Tab”](#) on page A-8.

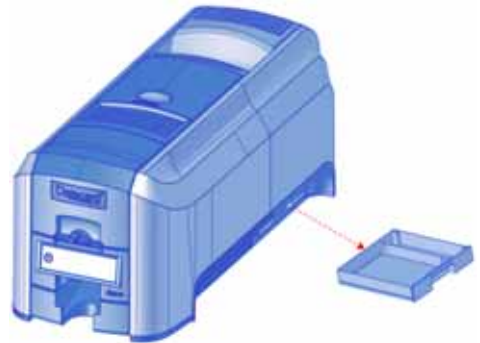

CD800 Printers With Locks

Do one of the following:

1. Remove the reject tray from the printer.
2. If you received a replacement reject tray without a tray floor, insert the new tray into your printer.

OR

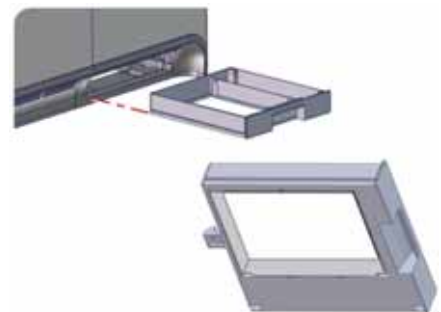

1. Remove the reject tray from the printer.
2. Use a flathead screwdriver to remove the floor of the reject tray. The edges may be rough after removing the tray floor.
3. Replace the reject card tray in the printer.
4. Discard the removed tray floor.

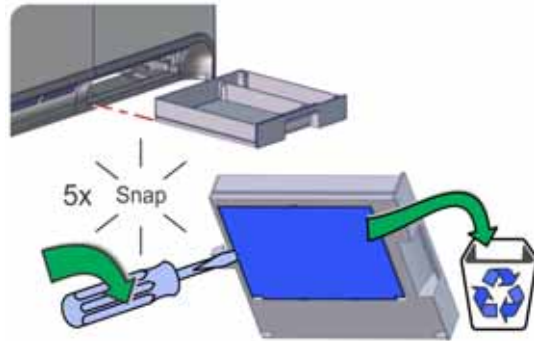

Remove the Interconnect Port Tab

The interconnect port on the left side of the printer may be covered by a plastic tab. Do the following to remove the tab so that you can connect the laminator cable to the printer.

 Do this only if necessary. The port tab may not be present in some printer models.

1. Locate the port tab on the left side of the printer.
2. Use a flathead screwdriver to remove the tab.
3. Discard the tab.

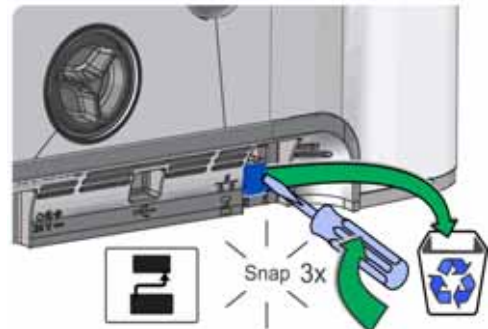

Remove the Mounting Lock Cover Tab

The mounting lock allows the printer to be locked to the laminator.



Do this only if necessary. The lock cover tab may not be present in some printer models.

To easily determine if the mounting lock cover tab is present, tip the printer onto its side and look at the shape of the of lock cover opening on the underside of the printer.



Remove the mounting lock cover tab.

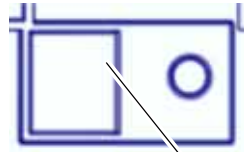

Mounting lock cover tab is not present. No action is necessary.

If you need to remove the mounting lock cover tab:

1. Carefully tip the printer onto its side.
2. Use a flathead screwdriver to remove the mounting lock cover tab from the bottom of the printer.
3. Return the printer to its upright position.
4. Discard the removed tab.

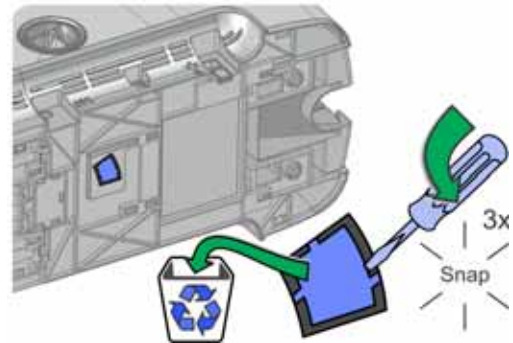

Replace the Output Hopper

Cards printed on a laminating system travel through the laminator and are ejected in the laminator output hopper. You can replace the printer output hopper with a blank insert to give the printer a more finished appearance.

 This procedure is optional.

1. Remove the output hopper tray by pulling it straight out from the printer.
2. Slide in the hopper insert shipped with the CLM laminator.

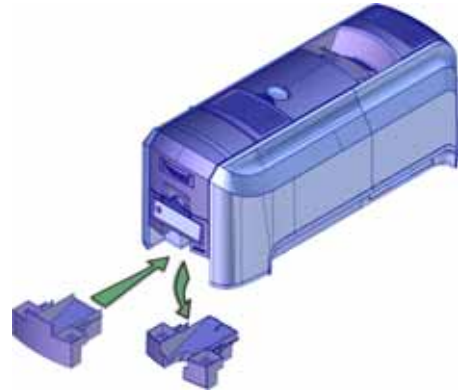

Install Vent Covers

The vent covers are supplied with the laminator to give the printer a finished appearance when it is mounted on the laminator.

Install the vent covers on the left and right sides of the printer. The covers snap into the vent openings. The left vent cover has a large opening to allow space to connect cables.

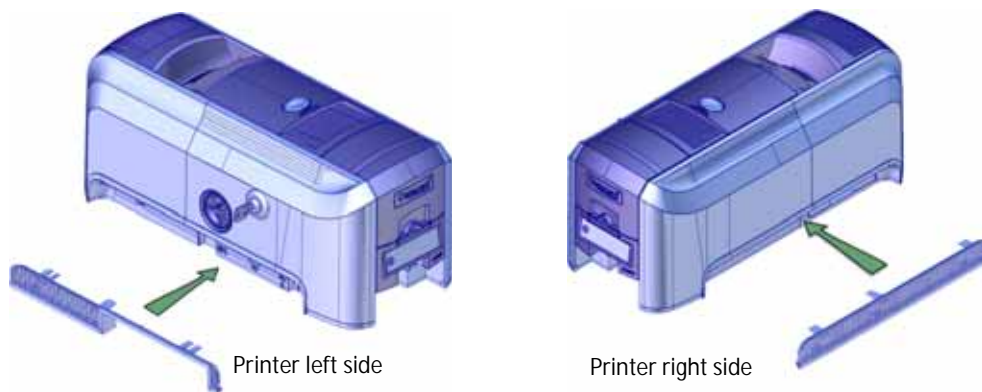

Continue with ["Assemble the Printer and Laminator"](#) on page A-11.

Assemble the Printer and Laminator

- 1. Locate the interconnect cable in the cable routing area of the laminator and make sure that it remains accessible.
- 2. Unlock and open the laminator access door.

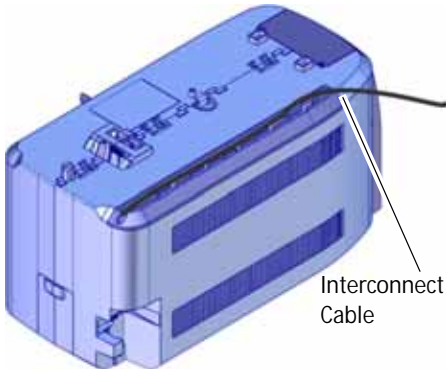

- 3. Slide the printer locking lever in the laminator to the left to move the mounting lock to the unlocked position.

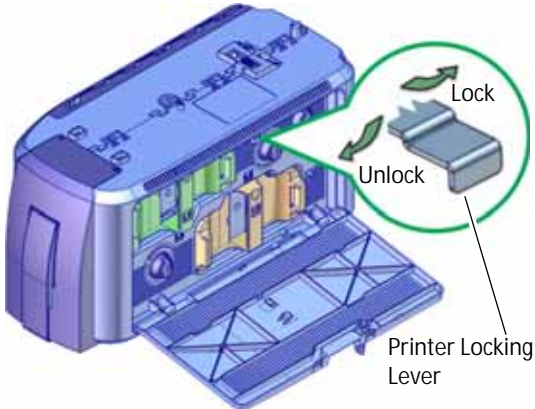

- 4. Lift the printer over the laminator and align the pins on the laminator with the holes on the underside of the printer.
- 5. Press down on the printer carefully, but firmly, to position it.
- 6. Push the printer locking lever to the right to lock the printer onto the laminator. Make sure that the printer is securely locked to the laminator.
- 7. Close and lock the laminator access door.

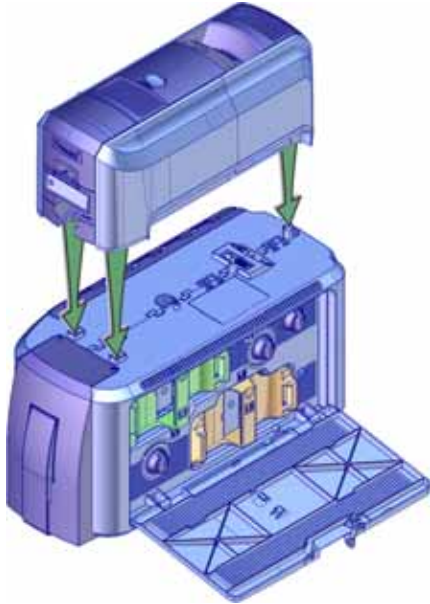

8. Connect the interconnect cable from the laminator to the lower port on the printer.



Connect the Power Cords

1. Connect the printer power cord to the printer and plug the power supply cord into the power outlet.

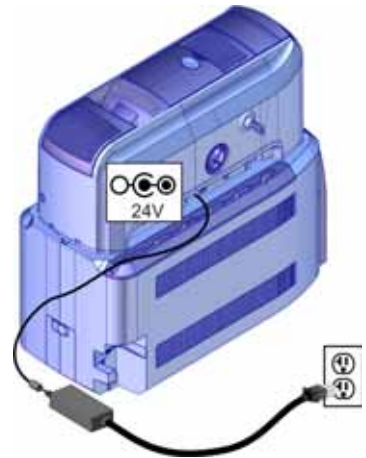

2. Connect the laminator power cord to the laminator and to the power supply. Plug the power supply cord into the power outlet.



Connect the System to a PC

You can connect the system to a Windows-based PC using either a USB cable or through a network via an Ethernet cable (the Ethernet cable is not supplied with the system).

Connect a USB Cable

1. Connect one end of the USB cable to the USB port of the printer.
2. Connect the other end to a USB port on the PC.



Do not connect the USB cable to the computer until the Card Printer Driver is installed on the PC, or when prompted during the driver installation. Refer to the printer's *Driver Guide* to set up the Card Printer Driver to work with the system.

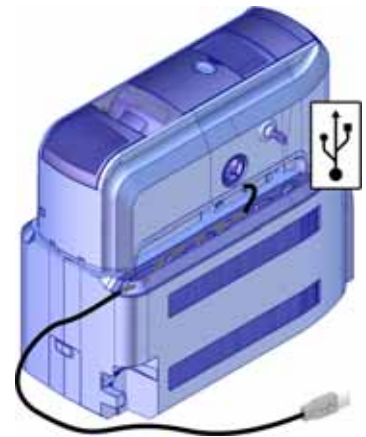

Connect a Network Cable

1. Connect one end of the Ethernet cable to the top port on the printer.
2. Connect the other end to a network port.
3. Refer to the printer's *Driver Guide* to set up the Card Printer Driver to work with the system. If you do not use the Card Printer Driver, refer to your ID software documentation for information about how to design cards and send jobs to the printer and laminator.

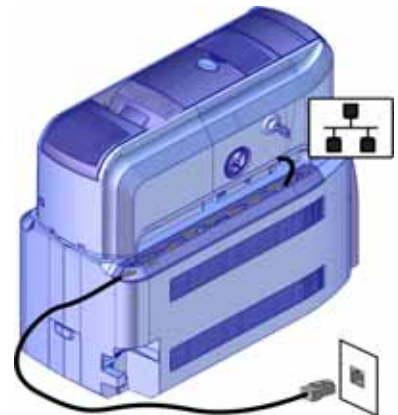

Load Laminator Overlay Material

Load the overlay material in one laminator cartridge at a time.

 The L1 (green) and L2 (orange) cartridges fit only in their assigned locations inside the laminator. They are not interchangeable.

1. Unlock and open the laminator access door.
2. Remove the L1 (green) laminator cartridge from the printer. Place the cartridge on a smooth, level surface for loading.

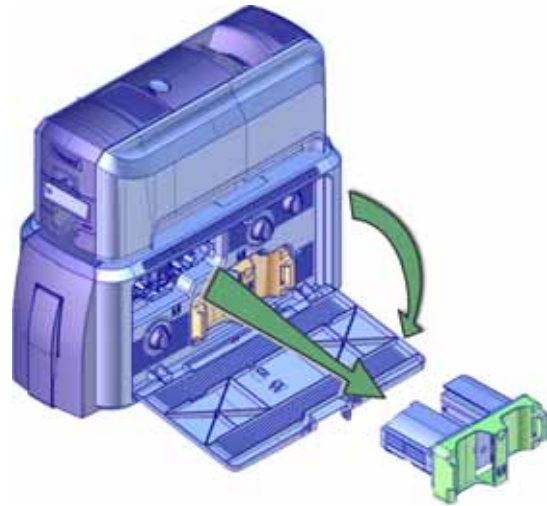

3. Push the release latch (a) and open the gate on the laminator cartridge (b).

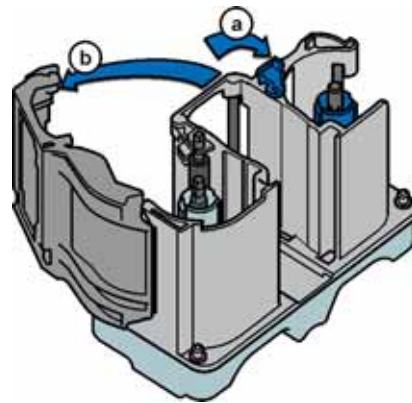

4. Load the new roll of laminator overlay material.
 - a. Put the blue supply spool on the blue supply spindle of the cartridge (c). The overlay supply roll can go on only one way and only fits on the correct spindle.
 - b. Put the empty silver take-up spool on the silver take-up spindle (d).
 - c. Turn the take-up spool clockwise to remove slack from the material (e). The overlay material loads in an S-shape.

Make sure that the overlay material is between the guides on both the take-up and supply sides of the cartridge.

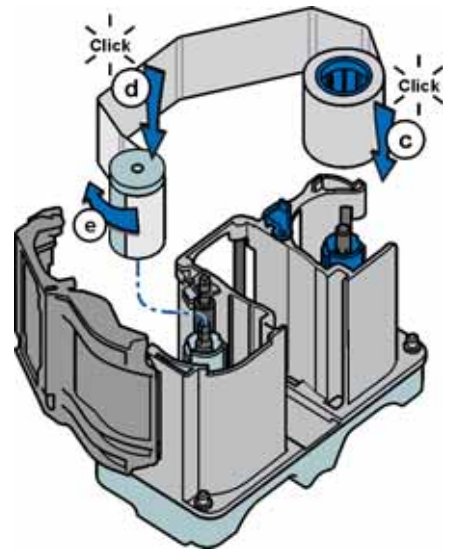

5. Close the laminator cartridge gate (f). Push it in until the latch clicks in place (g). Make sure that the overlay material is not pinched by the cartridge gate.
6. Replace the loaded laminator cartridge in the printer.
7. Remove the L2 (orange) cartridge from the laminator, if installed.
8. Repeat [step 3](#) through [step 6](#) to load the overlay onto the L2 cartridge.
9. Close and lock the laminator access door.

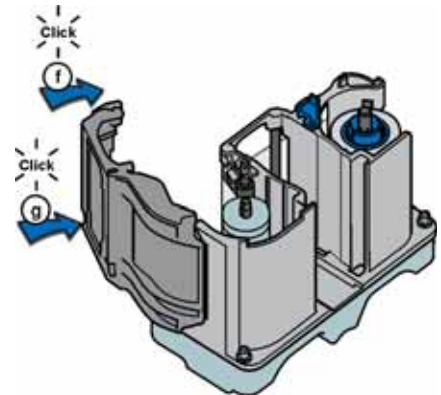

Power On the System

Press the power button on the front panel of the printer to power on the system. The printer and laminator perform internal checks and initialize supplies.



If message 222, Firmware version mismatch, displays on the printer LCD, refer to the *CD800 Card Printer CLM Laminator Quick Install and Upgrade Guide* for information about updating the printer and laminator firmware versions.

The laminator contains heaters for the L1 and L2 (if installed) cartridges, and for the impresser if one is installed. It can take several minutes for the heaters to reach their correct operating temperature before the system is ready to print cards.



The laminator has a power-save feature that powers off the heaters after the printer has been idle for a specified period of time. If the timeout period expires, it can take several minutes for the laminator heaters to return to their operating temperature when a card is sent to the printer. The front panel displays the message **Busy Warming up** during this time. You can change the timeout period using the Printer Manager Laminator setting. Refer to “[Laminator](#)” on [page 76](#) for more information about using Printer Manager.

Print a Test Card

After you set up the printer, print several test cards to determine how well the laminator applies the overlay material to the card. You may need to print multiple test cards to make sure that the overlay is positioned correctly. The card stock, the card design, and the printer's environment can influence the appearance of cards.



If your system includes the optional second laminator (L2), make sure that the laminator cartridge is always installed, even if the cartridge is not loaded with overlay material. If the cartridge is not in place, cards are not supported as they travel through the system, and can fall into the bottom of the laminator.

Use the Card Printer Driver

Refer to the printer's *Driver Guide* for information about how to set up lamination preferences and print a driver test card.

Use the Printer LCD Panel

Use the printer LCD panel to run a card that tests the L1 and L2 laminators (if L2 is installed), debows the card, and impresses the card if an impresser is installed. Do the following to print a test card from the printer LCD panel:

1. Press the USER button to enter the menu system.
2. **Suspended** displays on line 1 of the LCD panel. Press ENTER.
3. **Maintenance** displays on line 2. Press ENTER.
4. **Cleaning Card** displays on line 2. Press the down arrow key.
5. **Test Card** displays on line 2. Press ENTER.
6. **Start** displays on line 2. Press ENTER to print the test card.

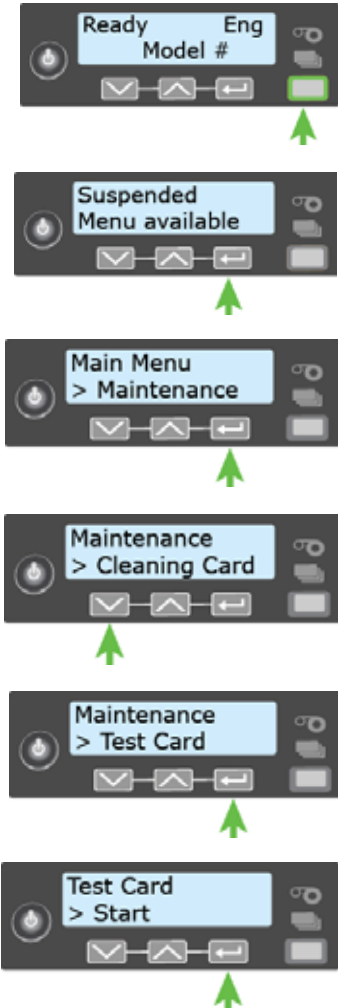

Use Printer Manager

Use Printer Manager to print test cards and fine-tune your lamination settings. Refer to [Chapter 3: "Printer Manager"](#) for complete information about accessing and using Printer Manager. Do the following to print a test card from Printer Manager:

1. Log on to Printer Manager.

a. Do one of the following:

- ◆ Open an Internet browser and enter the printer IP address:

IPv4: Enter the address using the following format: `https://xxx.xxx.xxx.xxx`.

For example, `https://172.12.3.45`.

IPv6: Enter the address using the following format:

`https://[xxxx:xxxx:xxxx:xxxx:xxxx:xxxx:xxxx:xxxx]/`

For example, `https://[2001:0db8:1234:5678:90ab:def0:1234:5678]/`



You must enclose the IPv6 address in brackets ([and]).

OR

- ◆ Open the **Printer Properties** window for the card printer and select the **Printer Status** tab.

Click **Configure Printer** to launch Printer Manager in your default browser.

If the browser indicates a problem with the website security certificate, continue to the website to access Printer Manager.

- b. Select **WebAdmin** from the drop-down menu and then click **Log In**.

2. Run a test card.
- a. Select **TroubleShooting > Test Card**.

- b. Select the print and lamination options you want to test, and then click **Run** to print a test card. You also can select to debow the test card, and impress the card if an impresser is installed.

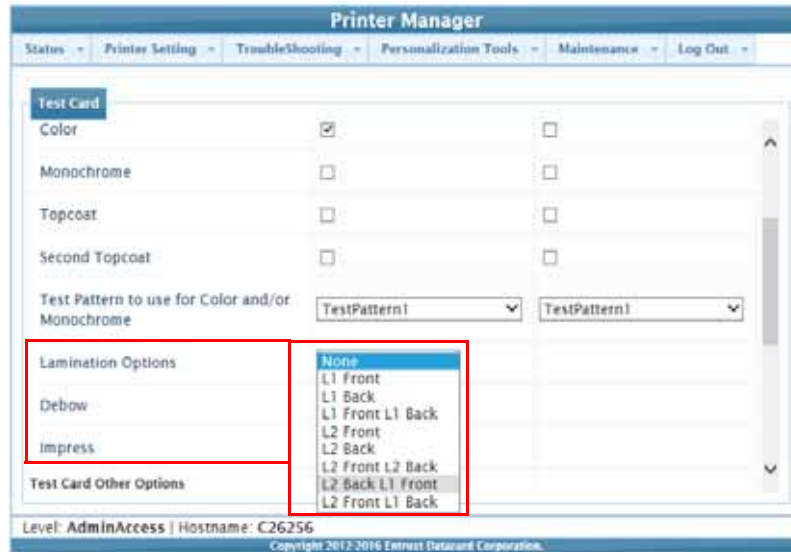

Verify the Test Card

Examine the test cards to verify the following.

- The overlays are being applied properly:
 - Each overlay is applied completely to the card.
 - The material adheres well to the edges of the card.
 - The overlay does not come off when the card is bent or twisted.
- The card is debowed correctly.
- The impression is positioned correctly and has the proper depth.

If you need to adjust the laminator settings, refer to the following Printer Manager sections: "[Laminator](#)" on [page 76](#) and "[LaminateType](#)" on [page 83](#).

